

Spur Gear

Pressure Angle 20°, Module 0.5, 0.8, 1.0, 1.5, 2.0, 2.5, 3.0, B Shape, Shaft Bore Fixed Type

■ Features: Compared with Straight Bore (GEAHBB), price is reduced and by making it in stock, next-day shipment can be realized.

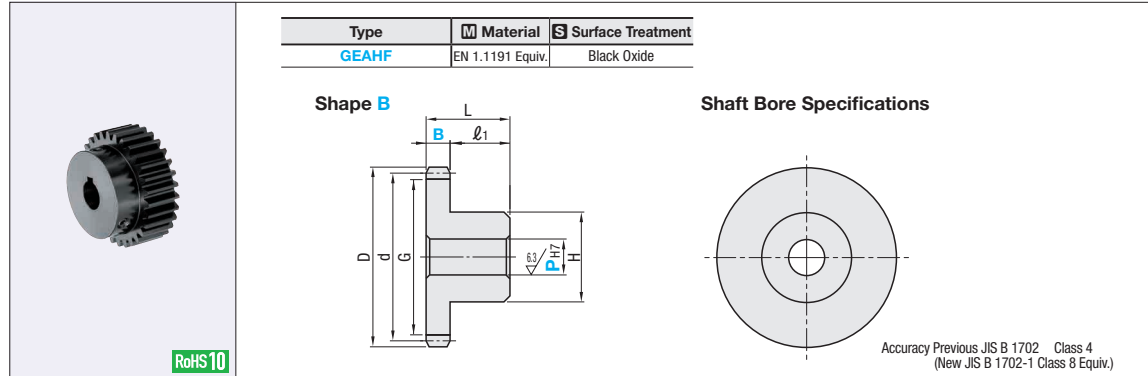

RoHS 10

Type	Material	Surface Treatment
GEAHF	EN 1.1191 Equiv.	Black Oxide

Shape B

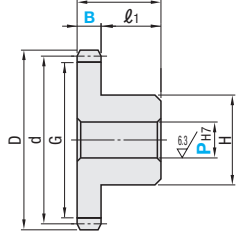

Shaft Bore Specifications

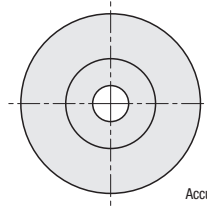

Accuracy Previous JIS B 1702 Class 4
(New JIS B 1702-1 Class 8 Equiv.)

■ Module 0.5 / 0.8 / 1.0 (For shaft bore free dimension parts, see P.1501 ~ P.1512; For configuration of the tooth width/hub dimensions, see P.1513.)

Part Number Type	Module	Number of Teeth	B	Gear Shape	Shaft Bore Dia. PH7	d Reference Dia.	D Tip Dia.	G Root Dia.	H	L	ℓ1	Unit Price		
GEAHF	0.5	28	3	B	3	14	15	12.75	10	8	5			
		30				15	13.75							
		32				16	14.75							
		35				17.5	16.25							
		36				18	16.75							
		40	20		18.75									
		42	21		19.75									
		45	22.5		21.25									
		48	24		22.75									
		50	25		23.75									
		52	26		24.75									
		60	30		28.75									
		70	35		33.75									
		80	40		38.75									
		100	50		48.75									
	0.8	20	7	4	5	16	17.6	14	12.5	14	7			
		24				19.2	20.8	17.2						
		25				20	21.6	18						
		28				22.4	24	20.4						
		30				24	25.6	22						
		32	25.6	27.2	23.6									
		36	28.8	30.4	26.8									
		40	32	33.6	30									
		45	36	37.6	34									
		48	38.4	40	36.4									
		50	40	41.6	38									
		1.0	20	12	6	8	20	22	17.5	20	20		8	
			21				21	23	18.5					
			22				22	24	19.5					
			23				23	25	20.5					
24	24		26				21.5							
25	25		27	22.5										
26	26		28	23.5										
27	27		29	24.5										
28	28		30	25.5										
29	29		31	26.5										
30	30		32	27.5										
	32		10	8	8	32	34	29.5	30	20	10			
	34					34	36	31.5						
	35					35	37	32.5						
	36					36	38	33.5						
	38	38				40	35.5							
	40	40	42	37.5										
	42	42	44	39.5										
	44	44	46	41.5										
	45	45	47	42.5										
	46	46	48	43.5										
	48	48	50	45.5										
	50	50	52	47.5										
	52	52	54	49.5										
	54	54	56	51.5										
	55	55	57	52.5										
56	56	58	53.5											
58	58	60	55.5											
60	60	62	57.5											
62	62	64	59.5											
64	64	66	61.5											
65	65	67	62.5											
66	66	68	63.5											
68	68	70	65.5											
70	70	72	67.5											
72	72	74	69.5											
75	75	77	72.5											
80	80	82	77.5											
84	84	86	81.5											
85	85	87	82.5											
90	90	92	87.5											
95	95	97	92.5											
96	96	98	93.5											
100	100	102	97.5											
110	110	112	107.5											
120	120	122	117.5											

■ Module 1.5 / 2.0 / 2.5 / 3.0 (For parts with selectable shaft bore dimension, see P.1501 ~ P.1512; For configuration of the tooth width/hub dimensions, see P.1513.)

Part Number Type	Module	Number of Teeth	B	Gear Shape	Shaft Bore Dia. PH7	d Reference Dia.	D Tip Dia.	G Root Dia.	H	L	ℓ1	Unit Price										
GEAHF	1.5	20	15	B	6	30	33	26.25	25	27	12											
		21				31.5	27.75															
		22				33	29.25															
		23				34.5	30.75															
		24				36	32.25															
		25				37.5	33.75															
		26				39	35.25															
		27				40.5	36.75															
		28				42	38.25															
		29				43.5	39.75															
		30				45	41.25															
		32				48	44.25															
		34				51	47.25															
		35				52.5	48.75															
		36				54	50.25															
		38				57	53.25															
		40				60	56.25															
		42				63	59.25															
		44				66	62.25															
		45				67.5	63.75															
		46				69	65.25															
		48				72	68.25															
		50				75	71.25															
		52				78	74.25															
		54				81	77.25															
		55			82.5	78.75																
		56			84	80.25																
		58			87	83.25																
		60			90	86.25																
		62			93	89.25																
		64			96	92.25																
		65			97.5	93.75																
		66			99	95.25																
		2.0			21	20	8	10	42	46	37		34	34	14							
					22				44	39												
					23				46	41												
					24				48	43												
					25				50	45												
					26				52	47												
					27				54	49												
					28				56	51												
					29				58	53												
					30				60	55												
					32				64	59												
					34				68	63												
					35				70	65												
					36				72	67												
					38				76	71												
					40				80	75												
					42				84	79												
	44		88		83																	
	45		90		85																	
	46		92		87																	
	2.5		20		25				8	10	50						55	43.75	41	41	16	
			21								52.5						46.25					
			22								55						48.75					
			23								57.5						51.25					
			24								60						53.75					
		25	62.5			56.25																
		26	65			58.75																
		27	67.5			61.25																
		28	70			63.75																
		29	72.5			66.25																
	30	75	68.75																			
	3.0	20	30		8	10	60	66	52.5	48	48		18									
		21					63	55.5														
		22					66	58.5														
		23					69	61.5														
		24					72	64.5														
		25					75	67.5														
		26					78	70.5														
		27					81	73.5														
		28					84	76.5														
		29					87	79.5														
	30	90	82.5																			



Ordering Example Part Number - Number of Teeth - B - Gear Shape - Shaft Bore Dia.
GEAHF1.0 - 40 - 10 - B - 8

Pinion mechanism by Round Gear Rack

