

Spacer / Spring Unit

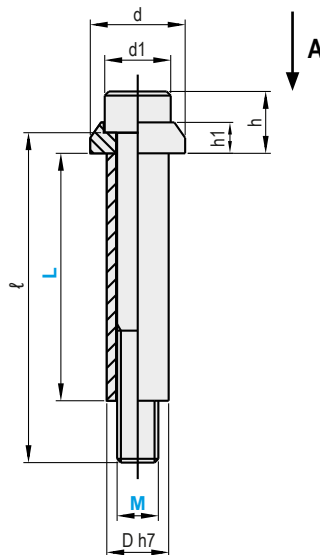

View A

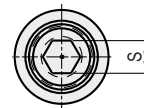

Spacer Sleeve:
M Tempering Steel
H 1200 - 1400 N/mm²

Cup Washer:
M Tempering Steel
H 1000 N/mm²

Socket-Head Cap Screw:
 DIN 912 / ISO 4762
M 12.9

⚠ Please note the screw tightening torque!
 See Table below.

d	d1	h	h1	ℓ	S	D	Catalog No.		L								
							Type	M									
15	10	10	5,5	35	5	10	SVC	M6	20								
				40					25								
				45					30								
				50					35								
				55					40								
				60					45								
				65					50								
				70					55								
				80					60								
				90					70								
				100					80								
				110					90								
				120					100								
19	13	13	6,5	45	6	12,5	SVC	M8	30								
				50					35								
				55					40								
				60					45								
				65					50								
				70					55								
				80					60								
				90					70								
				100					80								
				110					90								
				120					100								
				23					16	15	7,5	50	8	15	SVC	M10	30
												55					35
60	40																
65	45																
70	50																
75	55																
80	60																
90	70																
100	80																
110	90																
120	100																
140	120																

d	d1	h	h1	ℓ	S	D	Catalog No.		L
							Type	M	
27	18	18	9	60	10	17,5	SVC	M12	40
				65					45
				70					50
				80					55
				90					60
				100					70
				110					80
				120					90
				130					100
				140					110
				150					120
				170					140
				34					24
90	60								
100	70								
110	80								
120	90								
130	100								
140	110								
150	120								
180	140								
180	150								
200	160								

Catalog No.	L	Screw Tightening Torque for Steel 12.9 / [Nm]				
SVC M10	80	M6	M8	M10	M12	M16
SVC M16	150	13	32	65	120	290