

FAG

★ 23140-BE-XL-K

Spherical roller bearing

Schaeffler ID:
0599506680000

★ Preferred product

X-life

Spherical roller bearings 231...-E1-K, main dimensions to DIN 635-2, with tapered bore, taper 1:12

Technical information

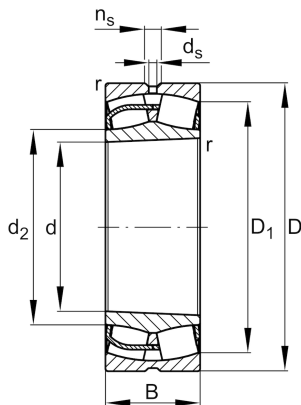

Temperature range

T_{min}	-30 °C	Operating temperature min.
-----------	--------	----------------------------

T_{max}	200 °C	Operating temperature max.
-----------	--------	----------------------------

	39 kg	Weight
--	-------	--------

Main Dimensions & Performance Data

d	200 mm	Bore diameter
D	340 mm	Outside diameter
B	112 mm	Width
C_r	1.610.000 N	Basic dynamic load rating, radial
C_{0r}	2.270.000 N	Basic static load rating, radial
C_{ur}	193.000 N	Fatigue load limit, radial
n_G	2.040 1/min	Limiting speed
n_{gr}	1.230 1/min	Reference speed

Dimensions

r_{min}	3 mm	Minimum chamfer dimension
D_1	295,8 mm	Bore diameter outer ring
d_2	230,4 mm	Raceway diameter of the inner ring
d_s	9,5 mm	Diameter lubrication hole
n_s	17,7 mm	Width of lubricating groove

Mounting dimensions

$d_{a min}$	214 mm	Minimum diameter shaft shoulder
$d_{a max}$	231 mm	Maximum diameter of shaft shoulder
$D_{a max}$	326 mm	Maximum diameter of housing shoulder
$r_{a max}$	2,5 mm	Maximum recess radius
$d_{b min}$	212 mm	Minimum cavity diameter of the sleeve
$B_{a min}$	10 mm	Minimum cavity width of the sleeve

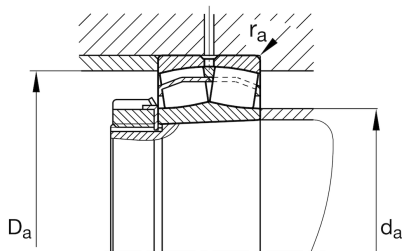

Additional information

	H3140	Adapter sleeve
e	0,32	Limiting value of Fa/Fr for the applicability of diff. Values of factors X and Y
Y ₁	2,1	Dynamic axial load factor
	AH3140	Withdrawal sleeve
Y ₂	3,13	Dynamic axial load factor
Y ₀	2,06	Static axial load factor