



## RME050-XL

### Flanged housing unit

Schaeffler ID:  
0009459510000

Housing units RME0, four-bolt flanged housing units, cast iron, centring spigot, eccentric locking collar, series 63, R seals

X-life

### Technical information

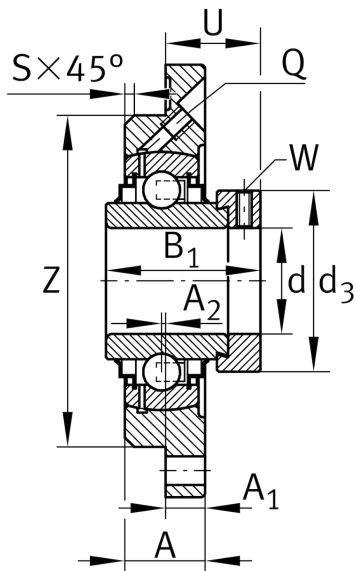
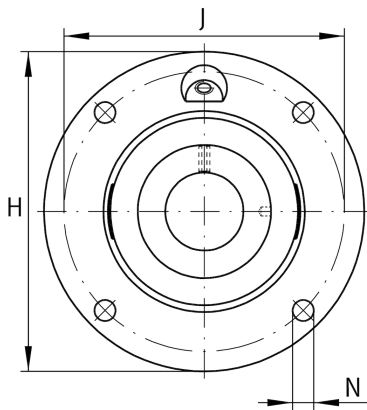

### Main Dimensions & Performance Data

d	50 mm	Bore diameter
H	230 mm	Height flange
B <sub>1</sub>	66,75 mm	Locking collar total width
U	44,6 mm	Total height unit
C <sub>r</sub>	66.000 N	Basic dynamic load rating, radial
C <sub>0r</sub>	38.000 N	Basic static load rating, radial
C <sub>ur</sub>	1.970 N	Fatigue load limit, radial
	5,66 kg	Weight

### Dimensions

A	31 mm	Height housing
	1	Number of housings
A <sub>1</sub>	19 mm	Thickness of flange
A <sub>2</sub>	-2,5 mm	Distance raceway
	MEO10	Housing
	GNE50-XL-KRR-B	Bearing designation
S	2 mm	Chamfer width
Q	M6	Connection thread lubrication

### Mounting dimensions

J	187 mm	Pitch circle diameter (holes)
N	23 mm	Fixing bore
Z	140 mm	Diameter spigot
	h8	Diameter spigot clearance
n	4	Number of screwing holes