

Adjusting gibs VUS38134-A (Series VUS)

adjusting gib for linear roller bearings

The datasheet is only an overview of dimensions and basic load ratings of the selected product. Please always observe all the guidelines in these overview pages. Further information is given on many products under the menu item "Description". You can also order comprehensive information via the Catalogue ordering system (https://www.schaeffler.de/content.schaeffler.de/en/news_media/index.jsp) or by telephone on +49 (91 32) 82 - 28 97.

L _{max}	141 mm
H _{min}	30 mm
B	51,5 mm
A ₃	28,25 mm
D ₂	6,9 mm
G ₂	<p>M8 for screws to DIN ISO 4762-12.9</p> <p>Max. tightening torque [MA]:</p> <p>M3 = 1,8 Nm</p> <p>M4 = 5 Nm</p> <p>M5 = 10 Nm</p> <p>M6 = 17 Nm</p> <p>M8 = 41 Nm</p> <p>M10 = 83 Nm</p> <p>M14 = 220 Nm</p> <p>The stated torques represent maximum values for the reliable transmission of forces in vibration-free, quasistatic applications (S0=1). We recommend that the tightening torques of the screw connection to the adjacent construction should be determined at the customer under the specific application conditions and operating conditions, observing the data in VDI Guideline 2230</p>

		Part 1 (2015) and the data in the description.
G3	M6	<p>for screws to DIN ISO 4762-12.9</p> <p>Max. tightening torque [MA]:</p> <p>M3 = 1,8 Nm</p> <p>M4 = 5 Nm</p> <p>M5 = 10 Nm</p> <p>M6 = 17 Nm</p> <p>M8 = 41 Nm</p> <p>M10 = 83 Nm</p> <p>M14 = 220 Nm</p> <p>The stated torques represent maximum values for the reliable transmission of forces in vibration-free, quasistatic applications (S0=1). We recommend that the tightening torques of the screw connection to the adjacent construction should be determined at the customer under the specific application conditions and operating conditions, observing the data in VDI Guideline 2230 Part 1 (2015) and the data in the description.</p>
JB	41 mm	Tolerance: +0,1/-0,1
JL	51 mm	Tolerance: +0,1/-0,1
JL2	28 mm	
JL5	30,5 mm	
K3	M6	<p>for screws to DIN ISO 4762-12.9</p> <p>Max. tightening torque [MA]:</p> <p>M3 = 1,8 Nm</p> <p>M4 = 5 Nm</p> <p>M5 = 10 Nm</p> <p>M6 = 17 Nm</p> <p>M8 = 41 Nm</p> <p>M10 = 83 Nm</p> <p>M14 = 220 Nm</p> <p>The stated torques represent maximum values for the reliable transmission of forces in vibration-free, quasistatic applications (S0=1). We recommend that the tightening torques of the screw connection to the adjacent construction should be determined at</p>

	the customer under the specific application conditions and operating conditions, observing the data in VDI Guideline 2230 Part 1 (2015) and the data in the description.	
L ₁	115 mm	
L _{2 max}	131 mm	
N ₃	5 mm	Through lubrication hole, use of sealing rings not necessary.
N ₄	22 mm	
Q _{1 max}	8 mm	
S ₁	8 mm	S = hexagon socket
S ₂	4 mm	S = hexagon socket Locking and extraction screw Depending on the size, socket head screws to DIN ISO 4762 or grub screws to DIN ISO 4026 are used.
T ₅	7 mm	
m	1,47 kg	≈ Mass
Δh _{max}	0,4 mm	Adjustment
	0,062 mm	Adjustment per screw revolution

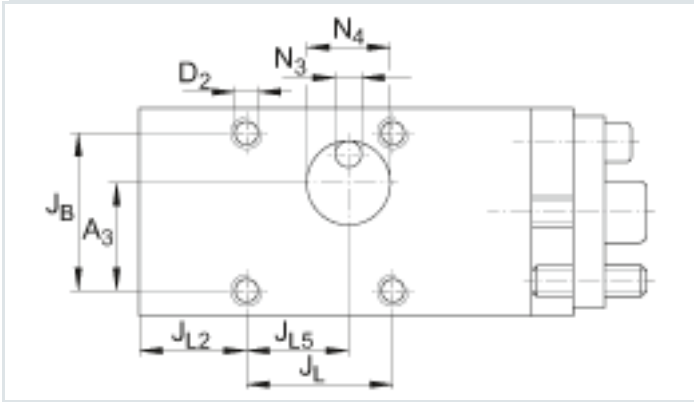
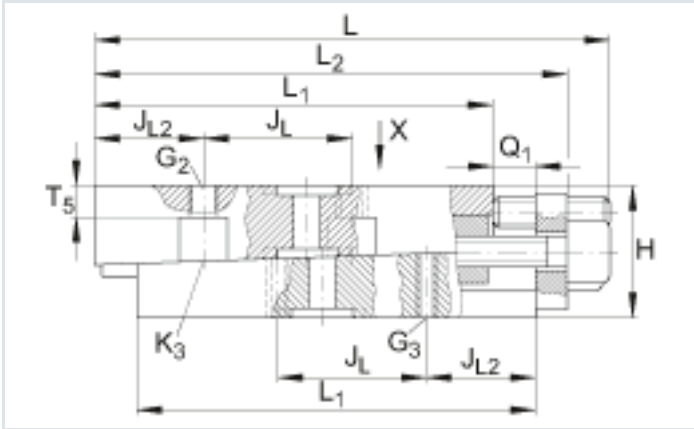
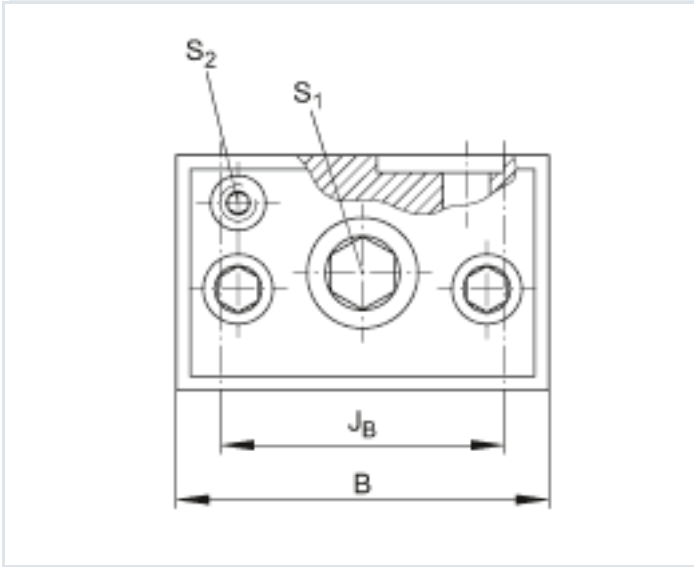

View X