



IMAGE
COMING SOON



PCJ45-XL-FA125

Flanged housing unit

Schaeffler ID:
0035075300000

Housing units PCJ...-FA125, four-bolt flanged housing units, cast iron, eccentric locking collar, P seals, with anti-corrosion protection

X-life

Technical information

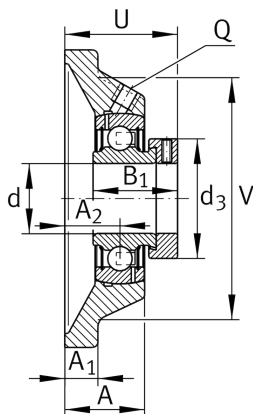
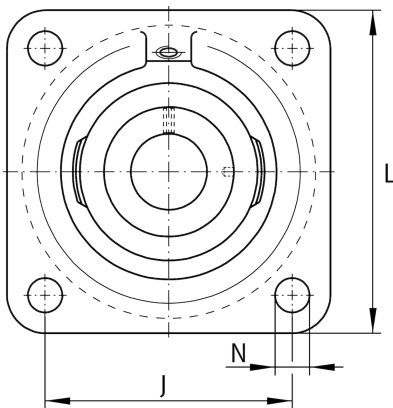

Main Dimensions & Performance Data

d	45 mm	Bore diameter
L	137 mm	Flange width
U	56,7 mm	Total height unit
C_r	34.500 N	Basic dynamic load rating, radial
C_{0r}	20.400 N	Basic static load rating, radial
C_{ur}	1.060 N	Fatigue load limit, radial
	2,22 kg	Weight

Dimensions

A	35 mm	Height housing
	1	Number of housings
A_1	13 mm	Thickness of flange
A_2	24 mm	Distance raceway
	CJ09	Housing
	GRAE45-XL-NPP-B-	Bearing designation
	FA125	
V	116 mm	Shoulder diameter housing
Q	Rp1/8	Connection thread lubrication
d_3	63 mm	Outside diameter eccentric locking collar

Mounting dimensions

J	105 mm	Distance fixing bore
N	14 mm	Fixing bore
n	4	Number of screwing holes