



★ RTUE100-XL

Take-up housing unit

Schaeffler ID:
0008776890000

★ Preferred product

Take-up housing units RTUE, cast iron housing, radial insert ball bearing with eccentric locking collar, R seals

X-life

Technical information

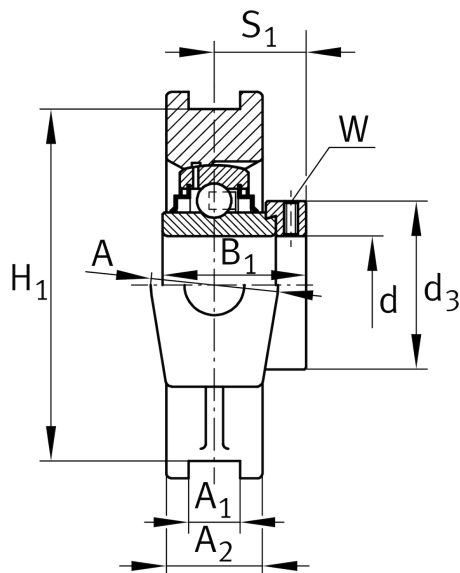
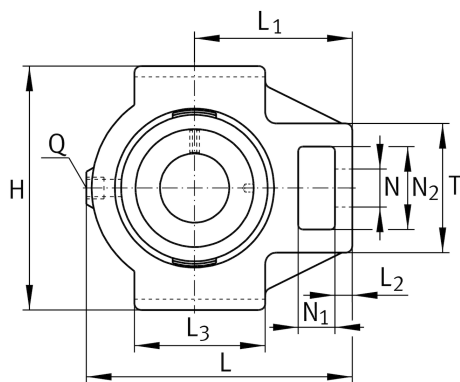

Main Dimensions & Performance Data

d	100 mm	Bore diameter
H	240 mm	Height
L	295 mm	Length total
	15,51 kg	Weight

Dimensions

L ₁	180 mm	Distance shaft axis
L ₂	30 mm	Length fixed link
L ₃	160 mm	Length guidance groove
A	90 mm	Width housing fixing side
N ₁	40 mm	Width recess
N ₂	80 mm	Height recess
T	130 mm	Height housing fixing side
Q	M6	Connection thread lubrication
A ₂	60 mm	Width housing

Mounting dimensions

A ₁	28 mm	Width guidance groove
	H13	Width guidance groove clearance
H ₁	215 mm	Distance guidance grooves
	0,25 mm	Upper distance guidance groove tolerance
	-0,25 mm	Lower distance guidance groove tolerance
N	47 mm	Fixing bore

Additional information

TUE20	Housing
GE100-XL-KRR-B	Bearing designation