



★ RCJT45-XL

Flanged housing unit

Schaeffler ID:
0008308950000

Housing units RCJT, two-bolt flanged housing units, cast iron, eccentric locking collar, R seals

★ Preferred product

X-life

Technical information

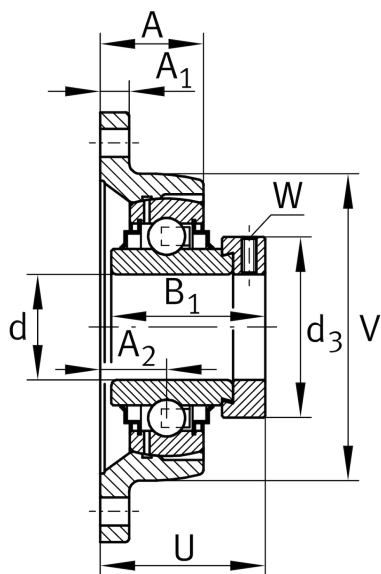
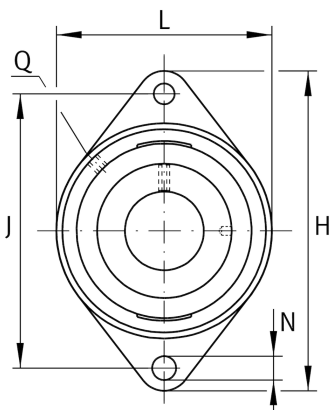

Main Dimensions & Performance Data

d	45 mm	Bore diameter
L	111 mm	Flange width
H	180 mm	Height flange
U	59,1 mm	Total height unit
C _r	34.500 N	Basic dynamic load rating, radial
C _{0r}	20.400 N	Basic static load rating, radial
C _{ur}	1.060 N	Fatigue load limit, radial
	1,87 kg	Weight

Dimensions

A	35 mm	Height housing
A ₁	13 mm	Thickness of flange
A ₂	24 mm	Distance raceway
V	111 mm	Shoulder diameter housing
Q	Rp1/8	Connection thread lubrication
d ₃	63 mm	Outside diameter eccentric locking collar

Mounting dimensions

J	148,5 mm	Distance fixing bore
N	14 mm	Fixing bore
n	2	Number of screwing holes

Additional information

	1	Number of housings
	CJT09	Housing
	GE45-XL-KRR-B	Bearing designation