



★ PCCJ25

Flanged housing unit

Schaeffler ID:
0008905100000

★ Preferred product

Housing units PCCJ, four-bolt flanged housing units, cast iron, double row angular contact ball bearing, P seals

Technical information

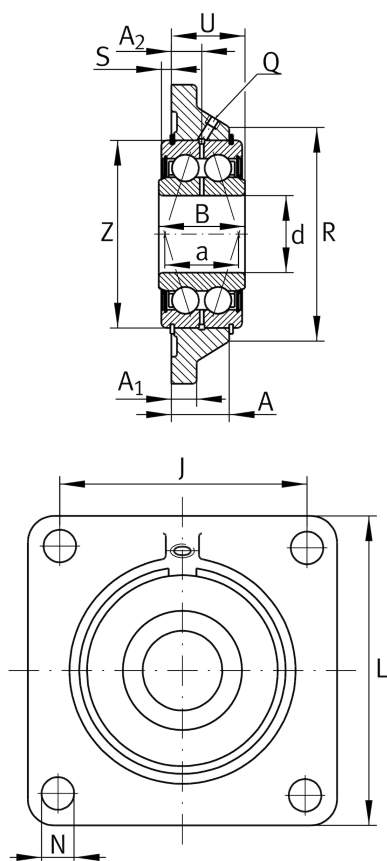

Main Dimensions & Performance Data

d	25 mm	Bore diameter
L	95 mm	Flange width
U	26,7 mm	Total height unit
C _r	21.600 N	Basic dynamic load rating, radial
C _{0r}	14.900 N	Basic static load rating, radial
C _{ur}	780 N	Fatigue load limit, radial
	0,89 kg	Weight

Dimensions

A	22,1 mm	Height housing
A ₁	12 mm	Thickness of flange
A ₂	11,7 mm	Distance raceway
B	30 mm	Width
Q	M6	Connection thread lubrication

Mounting dimensions

J	70 mm	Distance fixing bore
N	11,5 mm	Fixing bore
n	4	Number of screwing holes

Additional information

	1	Number of housings
	CCJ05	Housing
	G5205-2RS-N	Bearing designation