



★ RMEY45-XL

Flanged housing unit

Schaeffler ID:
0009407630000

★ Preferred product

Housing units RMEY, four-bolt flanged housing units, cast iron, centring spigot, grub screws in inner ring, R seals

X-life

Technical information

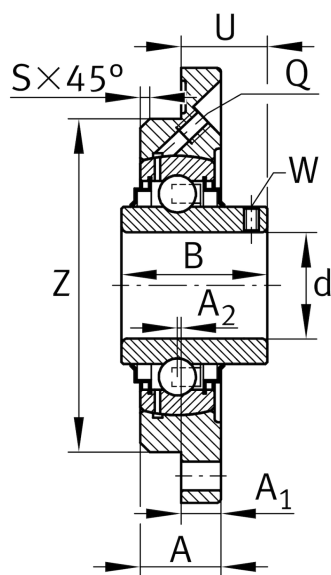
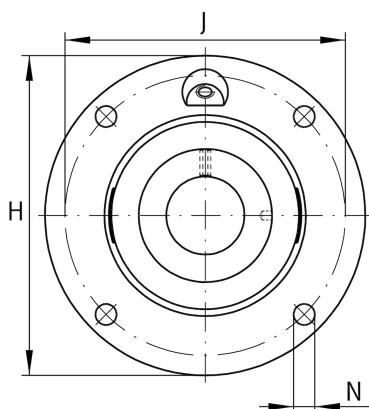

Main Dimensions & Performance Data

d	45 mm	Bore diameter
H	155 mm	Height flange
U	28,2 mm	Total height unit
C _r	32.500 N	Basic dynamic load rating, radial
C _{0r}	20.400 N	Basic static load rating, radial
C _{ur}	680 N	Fatigue load limit, radial
	1,88 kg	Weight

Dimensions

A	25 mm	Height housing
A ₁	12 mm	Thickness of flange
A ₂	2 mm	Distance raceway
B	49,2 mm	Width
S	2 mm	Chamfer width
Q	M6	Connection thread lubrication

Mounting dimensions

J	130 mm	Pitch circle diameter (holes)
N	14 mm	Fixing bore
Z	105 mm	Diameter spigot
	h8	Diameter spigot clearance
n	4	Number of screwing holes

Additional information

	1	Number of housings
	ME09	Housing
	GYE45-XL-KRR-B	Bearing designation