



## ★ RMEO40-XL

Flanged housing unit

Schaeffler ID:  
0009459430000

★ Preferred product

Housing units RMEO, four-bolt flanged housing units, cast iron, centring spigot, eccentric locking collar, series 63, R seals

X-life

### Technical information

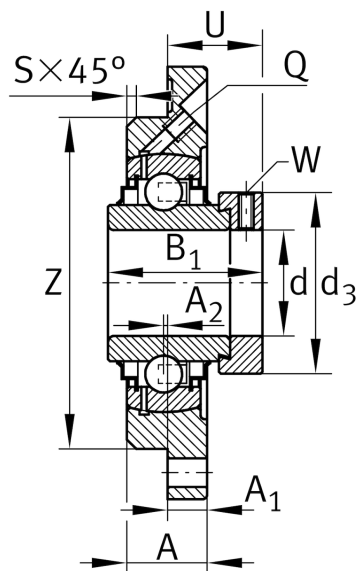
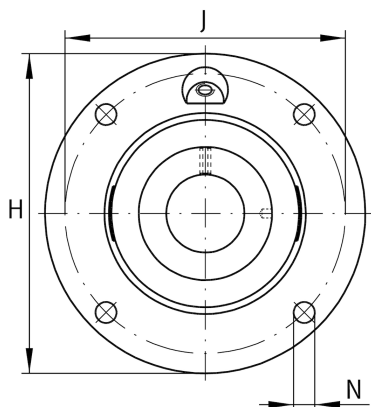

### Main Dimensions & Performance Data

d	40 mm	Bore diameter
H	194 mm	Height flange
B <sub>1</sub>	54,6 mm	Locking collar total width
U	39,1 mm	Total height unit
C <sub>r</sub>	44.500 N	Basic dynamic load rating, radial
C <sub>0r</sub>	26.000 N	Basic static load rating, radial
C <sub>ur</sub>	1.360 N	Fatigue load limit, radial
	3,35 kg	Weight

### Dimensions

A	27 mm	Height housing
A <sub>1</sub>	17 mm	Thickness of flange
A <sub>2</sub>	-2,5 mm	Distance raceway
S	2 mm	Chamfer width
Q	M6	Connection thread lubrication

### Mounting dimensions

J	158 mm	Pitch circle diameter (holes)
N	19 mm	Fixing bore
Z	115 mm	Diameter spigot
	h8	Diameter spigot clearance
n	4	Number of screwing holes

### Additional information

	1	Number of housings
	MEO08	Housing
	GNE40-XL-KRR-B	Bearing designation