

## ★ TASE80-XL

Plummer block housing unit

Schaeffler ID:  
0009791550000

★ Preferred product

Plummer block housing units TASE, cast iron housing, radial insert ball bearing with eccentric locking collar, T seals

X-life

### Technical information

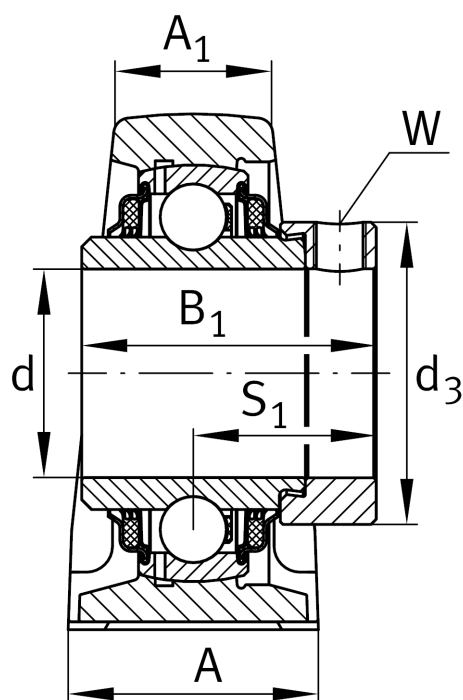
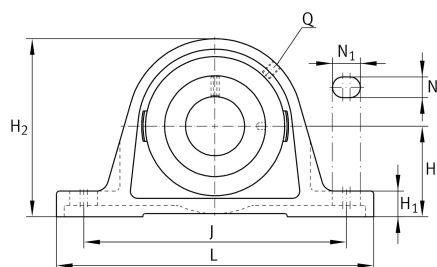

### Main Dimensions & Performance Data

d	80 mm	Bore diameter
L	290 mm	Length total
H <sub>2</sub>	175 mm	Height
	8,65 kg	Weight

### Dimensions

H	89 mm	Distance shaft axis
A	78 mm	Width (base)
A <sub>1</sub>	55 mm	Width (head)
H <sub>1</sub>	30 mm	Height (base)
Q	Rp1/8	Connection thread lubrication

### Mounting dimensions

J	232 mm	Distance fixing bore
N	26 mm	Width (slot)
N <sub>1</sub>	34 mm	Length (slot)

### Additional information

ASE16	Housing
GE80-XL-KTT-B	Bearing designation