



★ TME80-XL

Flanged housing unit

Schaeffler ID:
0009832170000

★ Preferred product

Housing units TME, four-bolt flanged housing units, cast iron, centring spigot, eccentric locking collar, T seals

X-life

Technical information

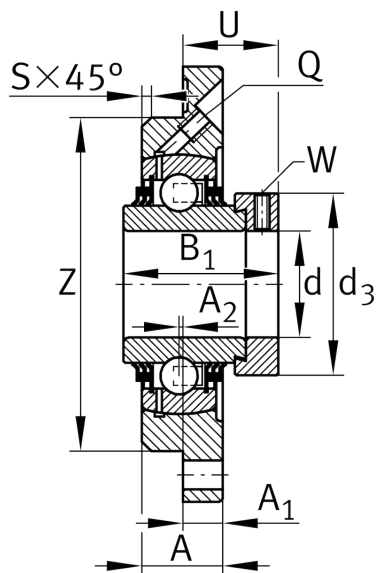
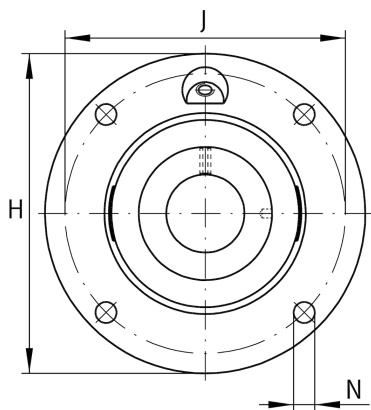

Main Dimensions & Performance Data

| | | |
|-----------------|----------|-----------------------------------|
| d | 80 mm | Bore diameter |
| H | 220 mm | Height flange |
| B ₁ | 70,7 mm | Locking collar total width |
| U | 49,3 mm | Total height unit |
| C _r | 76.000 N | Basic dynamic load rating, radial |
| C _{0r} | 54.000 N | Basic static load rating, radial |
| C _{ur} | 2.700 N | Fatigue load limit, radial |
| | 5,49 kg | Weight |

Dimensions

| | | |
|----------------|-------|-------------------------------|
| A | 31 mm | Height housing |
| A ₁ | 18 mm | Thickness of flange |
| A ₂ | -2 mm | Distance raceway |
| S | 6 mm | Chamfer width |
| Q | M6 | Connection thread lubrication |

Mounting dimensions

| | | |
|---|--------|-------------------------------|
| J | 164 mm | Distance fixing bore |
| J | 184 mm | Pitch circle diameter (holes) |
| N | 18 mm | Fixing bore |
| Z | 160 mm | Diameter spigot |
| | h8 | Diameter spigot clearance |
| n | 4 | Number of screwing holes |

Additional information

| | | |
|--|---------------|---------------------|
| | 1 | Number of housings |
| | GG.ME16 | Housing |
| | GE80-XL-KTT-B | Bearing designation |