

## VSSC6TRSL24VAC/DC0.5A

**Weidmüller Interface GmbH & Co. KG**  
 Klingenbergstraße 26  
 D-32758 Detmold  
 Germany

www.weidmueller.com



Similar to illustration

Overvoltage coupling along the conductor path may disturb or destroy sensitive signal inputs. It is important to provide protection in the immediate vicinity of I&C devices. Weidmüller's broad product range for the I&C sector offers products in a 2-piece, pluggable design and modular terminals for tension clamp or screw connection. These products are suitable for both binary and analogue signals. Weidmüller also offers other designs with integrated components such as gas discharge tubes or varistors. VARITECTOR stands for flexible and variable surge protection by Weidmüller, tested according to product standard IEC61643-21. The VARITECTOR series can be used in applications according to IEC 61643-22 / VDE 0845-3 for classes C1, C2, C3 and D1. The VARITECTOR SPC, SSC and MCZ OVP product families optimally combine electrical and mechanical properties. Size and easy handling play an important role. This surge protection is suited for confined spaces in industrial and process automation as well as in building automation applications.

### General ordering data

Version	Surge protection for instrumentation and control, Surge protection for measurement and control, U <sub>p</sub> (L/N-PE) 150 V
Order No.	<a href="#">1354790000</a>
Type	VSSC6TRSL24VAC/DC0.5A
GTIN (EAN)	4050118156744
Qty.	10 Stück

## VSSC6TRSL24VAC/DC0.5A

**Weidmüller Interface GmbH & Co. KG**  
 Klingenbergstraße 26  
 D-32758 Detmold  
 Germany

www.weidmueller.com

## Technische Daten

### Dimensions and weights

Depth	81 mm	Depth (inches)	3.189 inch
Height	88.5 mm	Height (inches)	3.484 inch
Width	6.2 mm	Width (inches)	0.244 inch
Net weight	47 g		

### Temperatures

Storage temperature	-40 °C...80 °C	Operating temperature	-40 °C...70 °C
Operating temperature, min.	-40 °C	Operating temperature, max.	70 °C
Humidity	5...96 %		

### Probability of failure

SIL in compliance with IEC 61508	3	MTTF	1,358 Jahre
SFF	96.67 %	λges	54
PFH in 1*10 <sup>-9</sup> per hour	1.8		

### Rated data UL

Certificate No. (UL)	E311081	UL certificate	UL Zertifikat
----------------------	---------	----------------	---------------

### CSA protection data

Gas group C	IIB	Gas group D	IIA
Gas groups A, B	IIC	Input current, max. I <sub>i</sub>	500 mA
Input voltage, max. U <sub>i</sub>	42 V	Internal capacity, max. C <sub>i</sub>	2 nF
Internal inductance, max. L <sub>i</sub>	0 μH		

### General data

Colour	black	Design	Terminal
Isolating function	Yes	Operating altitude	≤ 2000 m
Optical function display	No	Protection degree	IP20
Rail	TS 35	Segment	Measurement - Monitoring - Setting
Testing option	Functional screw with test plug receptacle, connections 1, 2, 4, 5	UL 94 flammability rating	V-0
Version	Surge protection for measurement and control		

### Insulation coordination acc. to EN 50178

Pollution severity	2	Surge voltage category	III
--------------------	---	------------------------	-----

## VSSC6TRSL24VAC/DC0.5A

**Weidmüller Interface GmbH & Co. KG**

Klingenbergstraße 26

D-32758 Detmold

Germany

www.weidmueller.com

## Technische Daten

### Rated data IEC / EN

Discharge current $I_{max}$ (8/20 $\mu$ s) wire-PE	10 kA	Discharge current $I_n$ (8/20 $\mu$ s) wire-PE	2.5 kA
Discharge current, max. (8/20 $\mu$ s)	20 kA	Fuse	0.5 A
Insertion loss	3.12 Mhz	Leakage current at $U_n$	2.8 mA
Lightning test current $I_{imp}$ (10/350 $\mu$ s)	1 kA	Lightning test current, $I_{imp}$ (10/350 $\mu$ s)	Wire-PE
Max. continuous voltage, $U_c$ (AC)	30 V	Wire-PE	1 kA
Number of poles	1	Max. continuous voltage, $U_c$ (DC)	42 V
Protection level $U_p$ (typ.)	150 V	Overload - failure mode	Modus 2
Protection level $U_p$ for C1 with 500V/250A (wire-wire)	116 V	Protection level $U_p$ for C1 with 500V/250A (wire-PE)	60 V
Protection level $U_p$ for C2 with 10kV/5kA (wire-wire)	204 V	Protection level $U_p$ for C2 with 10kV/5kA (wire-PE)	108 V
Protection level $U_p$ for C3 with 1kV/ $\mu$ s (wire-wire)	106 V	Protection level $U_p$ for C3 with 1kV/ $\mu$ s (wire-PE)	55 V
Pulse-reset capacity	$\leq 20$ ms	Protection level $U_p$ for D1 with 0.5kA (wire-wire)	194 V
Rated voltage (AC)	24 V	Rated current $I_N$	500 mA
Requirements category acc. to IEC 61643-21	C2, C3, D1	Rated voltage (DC)	34 V
Standards	IEC 61643-21	Signal transmission properties (-3 dB)	3.2 MHz
Surge current-carrying capacity C3	10 A 10/1000 $\mu$ s	Surge current-carrying capacity C2	2.5 kA 8/20 $\mu$ s 5 kV 1.2/50 $\mu$ s
Voltage type	AC/DC	Surge current-carrying capacity D1	1 kA 10/350 $\mu$ s
		Volume resistance	1.8 $\Omega$ 10 %

### Further details of approvals

GOST certificate	GOST-Zertifikat
------------------	-----------------

### Connection data

Type of connection	Screw connection	Tightening torque, min.	0.5 Nm
Tightening torque, max.	0.8 Nm	Clamping range, min.	0.5 mm <sup>2</sup>
Clamping range, max.	4 mm <sup>2</sup>	Wire cross-section, solid, min.	0.5 mm <sup>2</sup>
Wire cross-section, solid, max.	6 mm <sup>2</sup>	Conductor cross-section, flexible, AEH (DIN 46228-1), min.	0.5 mm <sup>2</sup>
Conductor cross-section, flexible, AEH (DIN 46228-1), max.	4 mm <sup>2</sup>	Connection cross-section, stranded, min.	0.5 mm <sup>2</sup>
Connection cross-section, stranded, max.	4 mm <sup>2</sup>		

### Ratings IECEx/ATEX/cUL

cUL certificate	cUL Certificate
-----------------	-----------------

### Classifications

ETIM 6.0	EC000943	ETIM 7.0	EC000943
ETIM 8.0	EC000943	ECLASS 9.0	27-13-08-07
ECLASS 9.1	27-13-08-07	ECLASS 10.0	27-13-08-07
ECLASS 11.0	27-13-08-07	ECLASS 12.0	27-17-90-90

## VSSC6TRSL24VAC/DC0.5A

**Weidmüller Interface GmbH & Co. KG**  
 Klingenbergstraße 26  
 D-32758 Detmold  
 Germany

www.weidmueller.com

## Technische Daten

### Tender specification sheets

Long specification	Short specification
<p>Surge protection in a one piece, 6.2 mm wide DIN rail module for two binary, potential-free signal circuits with 24 V UC. Each signal path can be opened using an isolator. Signal indication via a green LED. When the terminal is fitted, a simultaneous electrically conducting contact is made between the mounting rail (earth) and the reference potential (ground) of the protection circuit in the terminal. Optical identification of the terminal based on the type of protected switching and the voltage level. The terminal can be labelled or marked.</p>	<p>Surge protection in a one piece, 6.2 mm wide DIN rail module for two binary, potential-free signal circuits. Each signal path can be opened using an isolator. Signal indication via a green LED. Version: 24V UC</p>

### Environmental Product Compliance

REACH SVHC	Lead 7439-92-1
SCIP	71e97bb7-979f-4330-94c0-20c629bb05e3

### Important note

Product information	Mode 2: State where the voltage-limiting part of the SPD was short-circuited due to a very low impedance within the SPD. The line is inoperable, but the measuring equipment is still protected by means of a short-circuit.
---------------------	--

### Approvals

Approvals



ROHS	Conform
UL File Number Search	UL Website
Certificate No. (UL)	E31 1081

### Downloads

Approval/Certificate/Document of Conformity	<a href="#">SIL Paper</a> <a href="#">EU Konformitätserklärung / EU Declaration of Conformity</a>
Engineering Data	<a href="#">CAD data – STEP</a>
Engineering Data	<a href="#">WSCAD, EPLAN</a>
User Documentation	<a href="#">Beipackzettel / Instruction sheet</a>
Catalogues	<a href="#">Catalogues in PDF-format</a>
Brochures	

**VSSC6TRSL24VAC/DC0.5A**

**Weidmüller Interface GmbH & Co. KG**  
Klingenbergstraße 26  
D-32758 Detmold  
Germany

[www.weidmueller.com](http://www.weidmueller.com)

**Zeichnungen**

Similar to illustration

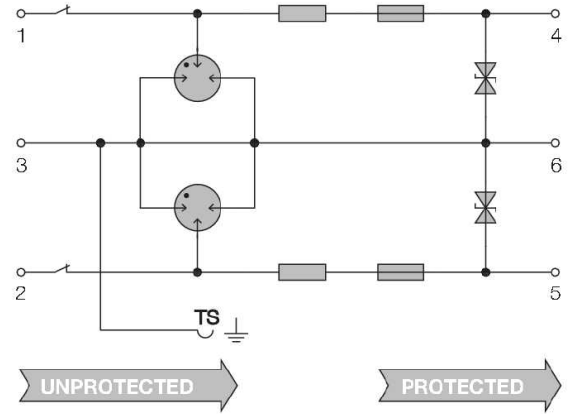

Circuit diagram