

**LP 5.00/02/135 4.5SN OR BX**

**Weidmüller Interfaces GmbH & Co. KG**

Postfach 3030

32760 Detmold

Tel. +49 5231 14-0

Fax. +49 5231 14-2083

info@weidmueller.com

www.weidmueller.com

**Product image**

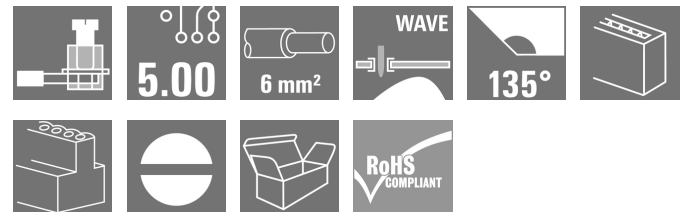
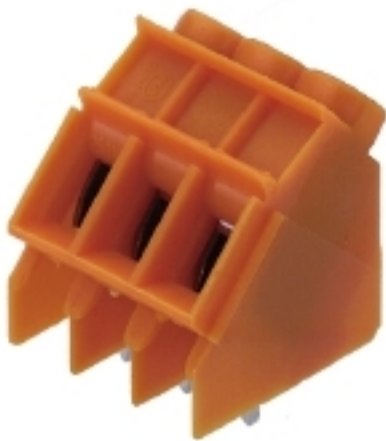

Similar to illustration

Test point, 32 A and 6 mm<sup>2</sup> conductor cross-section are feasible with this PCB terminal with proven clamping yoke connection at 5.00 and 5.08 mm pitch, conductor outlet direction 90° and 135°, with extensive auxiliary functions.

**General ordering data**

Version	Printed circuit board terminals, 5.00 mm, Number of poles: 2, 135°, Solder pin length (l): 4.5 mm, tinned, orange, Clamping yoke connection, Clamping range, max. : 6 mm <sup>2</sup> , Box
Order No.	<a href="#">1595760000</a>
Type	LP 5.00/02/135 4.5SN OR BX
GTIN (EAN)	4008190190224
Qty.	100 Stück
Product data	IEC: 500 V / 32 A / 0.5 - 6 mm <sup>2</sup> UL: 300 V / 20 A / AWG 26 - AWG 12
Packaging	Box

## LP 5.00/02/135 4.5SN OR BX

Weidmüller Interfaces GmbH & Co. KG

Postfach 3030

32760 Detmold

Tel. +49 5231 14-0

Fax. +49 5231 14-2083

info@weidmueller.com

www.weidmueller.com

## Technische Daten

### Dimensions and weights

Depth	17.5 mm	Depth (inches)	0.689 inch
Height	21.3 mm	Height (inches)	0.839 inch
Height of lowest version	16.8 mm	Width	10.6 mm
Width (inches)	0.417 inch	Net weight	3.35 g

### Temperatures

Operating temperature, min.	-50 °C	Operating temperature, max.	100 °C
-----------------------------	--------	-----------------------------	--------

### System parameters

Product family	OMNIMATE Signal - series LP	Wire connection method	Clamping yoke connection
Mounting onto the PCB	THT solder connection	Conductor outlet direction	135°
Pitch in mm (P)	5 mm	Pitch in inches (P)	0.197 inch
Number of poles	2	Pin series quantity	1
Fitted by customer	Yes	Number of rows	1
Max. adjacent poles per row	24	Solder pin length (l)	4.5 mm
Solder pin dimensions	0.75 x 0.9 mm	Solder eyelet hole diameter (D)	1.3 mm
Solder eyelet hole diameter tolerance (D)	+ 0,1 mm	Number of solder pins per pole	1
Screwdriver blade	0.6 x 3.5	Screwdriver blade standard	DIN 5264
Tightening torque, min.	0.5 Nm	Tightening torque, max.	0.6 Nm
Clamping screw	M 3	Stripping length	6 mm
L1 in mm	5 mm	L1 in inches	0.197 inch
Touch-safe protection acc. to DIN VDE 0470	IP 20	Touch-safe protection acc. to DIN VDE 57 106	Safe from finger touch
Protection degree	IP20	Volume resistance	1.20 mΩ

### Material data

Insulating material	PA	Colour	orange
Colour chart (similar)	RAL 2000	Insulating material group	I
Comparative Tracking Index (CTI)	≥ 600	UL 94 flammability rating	V-2
Contact material	Copper alloy	Contact surface	tinned
Coating	1-3 µm Ni, 4-6 µm SN	Tinning type	matt
Layer structure of solder connection	4...6 µm Ni / 4...6 µm Sn	Storage temperature, min.	-40 °C
Storage temperature, max.	70 °C	Operating temperature, min.	-50 °C
Operating temperature, max.	100 °C	Temperature range, installation, min.	-25 °C
Temperature range, installation, max.	100 °C		

### Conductors suitable for connection

Clamping range, min.	0.13 mm <sup>2</sup>
Clamping range, max.	6 mm <sup>2</sup>
Wire connection cross section AWG, min.	AWG 26
Wire connection cross section AWG, max.	AWG 12
Solid, min. H05(07) V-U	0.5 mm <sup>2</sup>
Solid, max. H05(07) V-U	6 mm <sup>2</sup>
Flexible, min. H05(07) V-K	0.5 mm <sup>2</sup>
Flexible, max. H05(07) V-K	4 mm <sup>2</sup>
w. plastic collar ferrule, DIN 46228 pt 4, min.	0.5 mm <sup>2</sup>
w. plastic collar ferrule, DIN 46228 pt 4, max.	2.5 mm <sup>2</sup>

Erstellungs-Datum May 30, 2023 2:17:36 PM CEST

## LP 5.00/02/135 4.5SN OR BX

Weidmüller Interfaces GmbH & Co. KG

Postfach 3030

32760 Detmold

Tel. +49 5231 14-0

Fax. +49 5231 14-2083

info@weidmueller.com

www.weidmueller.com

## Technische Daten

w. wire end ferrule, DIN 46228 pt 1, min. 0.5 mm<sup>2</sup>

w. wire end ferrule, DIN 46228 pt 1, max. 2.5 mm<sup>2</sup>

Plug gauge in accordance with EN 60999 a x b; ø 2.8 mm x 2.4 mm; 3.0 mm

Clampable conductor	Cross-section for conductor connection	Type	fine-wired	
		nominal	0.5 mm <sup>2</sup>	
		Stripping length	nominal 8 mm	
		Recommended wire-end ferrule	<a href="#">H0.5/12 OR</a>	
	wire end ferrule	Stripping length	nominal 6 mm	
		Recommended wire-end ferrule	<a href="#">H0.5/6</a>	
		Cross-section for conductor connection	Type	fine-wired
			nominal	0.75 mm <sup>2</sup>
	Stripping length		nominal 8 mm	
	Recommended wire-end ferrule		<a href="#">H0.75/12 W</a>	
	wire end ferrule	Stripping length	nominal 6 mm	
		Recommended wire-end ferrule	<a href="#">H0.75/6</a>	
Cross-section for conductor connection		Type	fine-wired	
		nominal	1 mm <sup>2</sup>	
	Stripping length	nominal 8 mm		
	Recommended wire-end ferrule	<a href="#">H1.0/12 GE</a>		
wire end ferrule	Stripping length	nominal 6 mm		
	Recommended wire-end ferrule	<a href="#">H1.0/6</a>		

Reference text Length of ferrules is to be chosen depending on the product and the rated voltage., The outside diameter of the plastic collar should not be larger than the pitch (P)

### Rated data acc. to IEC

tested acc. to standard	IEC 60664-1, IEC 61984	Rated current, min. number of poles (Tu=20°C)	32 A
Rated current, max. number of poles (Tu=20°C)	30.5 A	Rated current, min. number of poles (Tu=40°C)	32 A
Rated current, max. number of poles (Tu=40°C)	25 A	Rated voltage for surge voltage class / pollution degree II/2	500 V
Rated voltage for surge voltage class / pollution degree III/2	250 V	Rated voltage for surge voltage class / pollution degree III/3	250 V
Rated impulse voltage for surge voltage class/ pollution degree II/2	4 kV	Rated impulse voltage for surge voltage class/ pollution degree III/2	4 kV
Rated impulse voltage for surge voltage class/ contamination degree III/3	4 kV	Short-time withstand current resistance	3 x 1s with 120 A

### Rated data acc. to CSA

Institute (CSA)		Certificate No. (CSA)	200039-1202191
Rated voltage (Use group B / CSA)	300 V	Rated voltage (Use group D / CSA)	300 V
Rated current (Use group B / CSA)	20 A	Rated current (Use group D / CSA)	10 A
Wire cross-section, AWG, min.	AWG 26	Wire cross-section, AWG, max.	AWG 12
Reference to approval values	Specifications are maximum values, details - see approval certificate.		

Erstellungs-Datum May 30, 2023 2:17:36 PM CEST

## LP 5.00/02/135 4.5SN OR BX

Weidmüller Interfaces GmbH & Co. KG

Postfach 3030

32760 Detmold

Tel. +49 5231 14-0

Fax. +49 5231 14-2083

info@weidmueller.com

www.weidmueller.com

E60693

## Technische Daten

### Rated data acc. to UL 1059

Institute (UR)



Certificate No. (UR)

Rated voltage (Use group B / UL 1059)	300 V
Rated current (Use group B / UL 1059)	20 A
Wire cross-section, AWG, min.	AWG 26
Reference to approval values	Specifications are maximum values, details - see approval certificate.

Rated voltage (Use group D / UL 1059)	300 V
Rated current (Use group D / UL 1059)	10 A
Wire cross-section, AWG, max.	AWG 12

### Packing

Packaging	Box	VPE length	60 mm
VPE width	100 mm	VPE height	120 mm

### Classifications

ETIM 6.0	EC002643	ETIM 7.0	EC002643
ETIM 8.0	EC002643	ECLASS 9.0	27-44-04-01
ECLASS 9.1	27-44-04-01	ECLASS 10.0	27-44-04-01
ECLASS 11.0	27-46-01-01	ECLASS 12.0	27-46-01-01

### Important note

IPC conformity Conformity: The products are developed, manufactured and delivered according international recognized standards and norms and comply with the assured properties in the data sheet resp. fulfill decorative properties in accordance with IPC-A-610 "Class 2". Further claims on the products can be evaluated on request.

Notes

- Additional variants on request
- Rated current related to rated cross-section & min. No. of poles.
- Wire end ferrule without plastic collar to DIN 46228/1
- Wire end ferrule with plastic collar to DIN 46228/4
- P on drawing = pitch
- Rated data refer only to the component itself. Clearance and creepage distances to other components are to be designed in accordance with the relevant application standards.
- The test point can only be used as potential-pickup point.
- Long term storage of the product with average temperature of 50 °C and average humidity 70%, 36 months

### Approvals

Approvals



ROHS	Conform
UL File Number Search	UL Website
Certificate No. (UR)	E60693

Erstellungs-Datum May 30, 2023 2:17:36 PM CEST

Katalogstand 26.05.2023 / Technische Änderungen vorbehalten

**LP 5.00/02/135 4.5SN OR BX****Weidmüller Interfaces GmbH & Co. KG**

Postfach 3030

32760 Detmold

Tel. +49 5231 14-0

Fax. +49 5231 14-2083

[info@weidmueller.com](mailto:info@weidmueller.com)**Technische Daten****Downloads**

Product Change Notification	<a href="#">PCN_2016_273_PL32_Loss_of_nickle_LL_LP_Family_EN</a> <a href="#">PCN_2016_273_PL32_Wegfall_Unternickelung_LL_LP_Familie_DE</a>	<a href="http://www.weidmueller.com">www.weidmueller.com</a>
Catalogues	<a href="#">Catalogues in PDF-format</a>	
Brochures	<a href="#">FL DRIVES EN</a> <a href="#">FL DRIVES DE</a>	

LP 5.00/02/135 4.5SN OR BX

Weidmüller Interfaces GmbH & Co. KG

Postfach 3030

32760 Detmold

Tel. +49 5231 14-0

Fax. +49 5231 14-2083

Zeichnungen

Dimensional drawing [info@weidmueller.com](mailto:info@weidmueller.com)

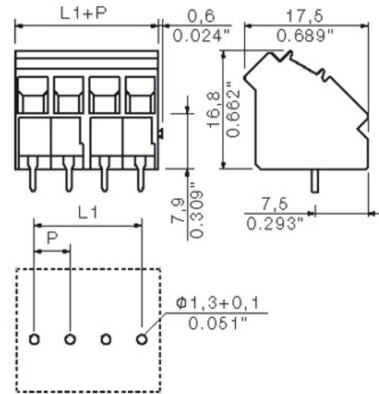

Graph

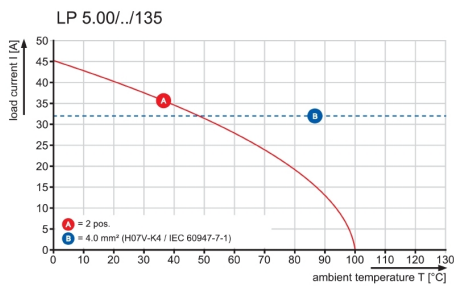

## Recommended wave soldering profiles

**Weidmüller Interface GmbH & Co. KG**  
 Klingenbergstraße 16  
 D-32758 Detmold  
 Germany  
 Fon: +49 5231 14-0  
 Fax: +49 5231 14-292083  
 www.weidmueller.com

### Single Wave:



### Double Wave:



### Wave soldering profiles

Wired connection elements should be processed in accordance with the DIN EN 61760-1 standard. We have included two recommendations for practical wave soldering profiles, with which Weidmüller PCB terminals and connectors are qualified.

When choosing a suitable profile for your application, the following factors also need to be considered:

- PCB thickness
- Proportion of Cu in the layers
- Single/double-sided assembly
- Product range
- Heating and cooling rates

The single and double wave profiles each indicate the recommended operating range, including the maximum soldering temperature of 260°C. In practice, the maximum soldering temperature is quite often well below the above maximum profile.