

**LU 10.16/03/90 4STI 3.2SN GY BX**

**Weidmüller Interfaces GmbH & Co. KG**

Postfach 3030

32760 Detmold

Tel. +49 5231 14-0

Fax. +49 5231 14-2083

info@weidmueller.com

www.weidmueller.com

**Product image**

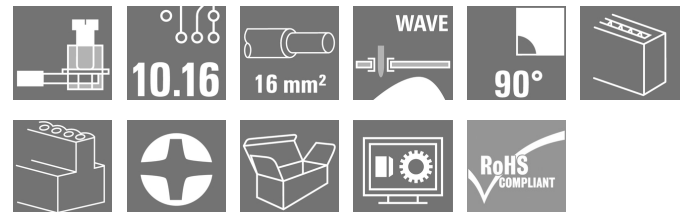

Similar to illustration

This PCB terminal provides connections for 76 A and 16 mm<sup>2</sup> conductor cross-section with proven clamping yoke connection at 10.16 mm pitch, conductor outlet direction in 90° design.

**General ordering data**

Version	Printed circuit board terminals, 10.16 mm, Number of poles: 3, 90°, Solder pin length (l): 3.2 mm, tinned, Pebble grey, Clamping yoke connection, Clamping range, max.: 16 mm <sup>2</sup> , Box
Order No.	<a href="#">1635930000</a>
Type	LU 10.16/03/90 4STI 3.2SN GY BX
GTIN (EAN)	4008190273453
Qty.	20 Stück
Product data	IEC: 1000 V / 76 A / 0.5 - 16 mm <sup>2</sup> UL: 300 V / 65 A / AWG 26 - AWG 6
Packaging	Box

## LU 10.16/03/90 4STI 3.2SN GY BX

Weidmüller Interfaces GmbH & Co. KG

Postfach 3030

32760 Detmold

Tel. +49 5231 14-0

Fax. +49 5231 14-2083

info@weidmueller.com

www.weidmueller.com

## Technische Daten

### Dimensions and weights

Depth	18.3 mm	Depth (inches)	0.72 inch
Height	31.7 mm	Height (inches)	1.248 inch
Height of lowest version	28.5 mm	Width	30.48 mm
Width (inches)	1.2 inch	Net weight	30.6 g

### Temperatures

Operating temperature, min.	-50 °C	Operating temperature, max.	120 °C
-----------------------------	--------	-----------------------------	--------

### System parameters

Product family	OMNIMATE Power - series LU	Wire connection method	Clamping yoke connection
Mounting onto the PCB	THT solder connection	Conductor outlet direction	90°
Pitch in mm (P)	10.16 mm	Pitch in inches (P)	0.4 inch
Number of poles	3	Pin series quantity	1
Fitted by customer	Yes	Number of rows	1
Max. adjacent poles per row	10	Solder pin length (l)	3.2 mm
Solder pin dimensions	1.2 x 1.2 mm	Solder pin dimensions = d tolerance	0 / -0,15 mm
Solder eyelet hole diameter (D)	1.6 mm	Solder eyelet hole diameter tolerance (D)	+ 0,1 mm
Number of solder pins per pole	4	Screwdriver blade	1.0 x 5.5
Screwdriver blade standard	DIN 5264	Tightening torque, min.	1.2 Nm
Tightening torque, max.	2.2 Nm	Clamping screw	M 4
Stripping length	12 mm	L1 in mm	20.32 mm
L1 in inches	0.8 inch	Touch-safe protection acc. to DIN VDE 0470	IP20 plugged/ IP10 unplugged
Touch-safe protection acc. to DIN VDE 57 106	Safe from finger touch	Protection degree	IP20
Volume resistance	0.50 mΩ		

### Material data

Insulating material	Wemid (PA)	Colour	Pebble grey
Colour chart (similar)	RAL 7032	Insulating material group	I
Comparative Tracking Index (CTI)	≥ 600	UL 94 flammability rating	V-0
Contact material	E-Cu	Contact surface	tinned
Layer structure of solder connection	1.5...3 µm Ni / 4...6 µm Sn matt	Storage temperature, min.	-40 °C
Storage temperature, max.	70 °C	Operating temperature, min.	-50 °C
Operating temperature, max.	120 °C	Temperature range, installation, min.	-25 °C
Temperature range, installation, max.	120 °C		

### Conductors suitable for connection

Clamping range, min.	0.14 mm <sup>2</sup>
Clamping range, max.	16 mm <sup>2</sup>
Wire connection cross section AWG, min.	AWG 22
Wire connection cross section AWG, max.	AWG 8
Solid, min. H05(07) V-U	0.5 mm <sup>2</sup>
Solid, max. H05(07) V-U	16 mm <sup>2</sup>
Stranded, min. H07V-R	6 mm <sup>2</sup>
Stranded, max. H07V-R	16 mm <sup>2</sup>
Flexible, min. H05(07) V-K	0.5 mm <sup>2</sup>
Flexible, max. H05(07) V-K	16 mm <sup>2</sup>

Erstellungs-Datum May 30, 2023 2:19:09 PM CEST

## LU 10.16/03/90 4STI 3.2SN GY BX

Weidmüller Interfaces GmbH & Co. KG

Postfach 3030

32760 Detmold

Tel. +49 5231 14-0

Fax. +49 5231 14-2083

info@weidmueller.com

www.weidmueller.com

### Technische Daten

w. plastic collar ferrule, DIN 46228 pt 4, 2.5 mm<sup>2</sup> min.

w. plastic collar ferrule, DIN 46228 pt 4, 10 mm<sup>2</sup> max.

w. wire end ferrule, DIN 46228 pt 1, 2.5 mm<sup>2</sup> min.

w. wire end ferrule, DIN 46228 pt 1, 10 mm<sup>2</sup> max.

Plug gauge in accordance with EN 60999 a x b; ø 5.4 mm x 5.1 mm; 5.3 mm

Clampable conductor	Cross-section for conductor connection	Type	fine-wired
		nominal	2.5 mm <sup>2</sup>
wire end ferrule	wire end ferrule	Stripping length	nominal 12 mm
		Recommended wire-end ferrule	<a href="#">H2.5/12</a>
		Stripping length	nominal 14 mm
		Recommended wire-end ferrule	<a href="#">H2.5/19D BL</a>
Cross-section for conductor connection	wire end ferrule	Type	fine-wired
		nominal	4 mm <sup>2</sup>
wire end ferrule	wire end ferrule	Stripping length	nominal 12 mm
		Recommended wire-end ferrule	<a href="#">H4.0/12</a>
		Stripping length	nominal 14 mm
		Recommended wire-end ferrule	<a href="#">H4.0/20D GR</a>
Cross-section for conductor connection	wire end ferrule	Type	fine-wired
		nominal	6 mm <sup>2</sup>
wire end ferrule	wire end ferrule	Stripping length	nominal 12 mm
		Recommended wire-end ferrule	<a href="#">H6.0/12</a>
		Stripping length	nominal 14 mm
		Recommended wire-end ferrule	<a href="#">H6.0/20 SW</a>
Cross-section for conductor connection	wire end ferrule	Type	fine-wired
		nominal	10 mm <sup>2</sup>
wire end ferrule	wire end ferrule	Stripping length	nominal 15 mm
		Recommended wire-end ferrule	<a href="#">H10.0/22 EB</a>
		Stripping length	nominal 12 mm
		Recommended wire-end ferrule	<a href="#">H10.0/12</a>

Reference text Length of ferrules is to be chosen depending on the product and the rated voltage. The outside diameter of the plastic collar should not be larger than the pitch (P)

### Rated data acc. to IEC

tested acc. to standard	IEC 60664-1, IEC 61984	Rated current, min. number of poles (Tu=20°C)	76 A
Rated current, max. number of poles (Tu=20°C)	72 A	Rated current, min. number of poles (Tu=40°C)	76 A
Rated current, max. number of poles (Tu=40°C)	62 A	Rated voltage for surge voltage class / pollution degree II/2	1,000 V
Rated voltage for surge voltage class / pollution degree III/2	690 V	Rated voltage for surge voltage class / pollution degree III/3	690 V
Rated impulse voltage for surge voltage class/ pollution degree II/2	4 kV	Rated impulse voltage for surge voltage class/ pollution degree III/2	6 kV
Rated impulse voltage for surge voltage class/ contamination degree III/3	6 kV	Short-time withstand current resistance	2 x 1s with 700 A

Erstellungs-Datum May 30, 2023 2:19:09 PM CEST

Katalogstand 26.05.2023 / Technische Änderungen vorbehalten

**LU 10.16/03/90 4STI 3.2SN GY BX**

Weidmüller Interfaces GmbH & Co. KG

Postfach 3030

32760 Detmold

Tel. +49 5231 14-0

Fax. +49 5231 14-2083

info@weidmueller.com

**Technische Daten**

**Rated data acc. to CSA**

Institute (CSA)



Certificate No. (CSA)

www.weidmueller.com

200039-1198743

Rated voltage (Use group B / CSA)	300 V
Rated voltage (Use group D / CSA)	300 V
Rated current (Use group C / CSA)	65 A
Wire cross-section, AWG, min.	AWG 22
Reference to approval values	Specifications are maximum values, details - see approval certificate.

Rated voltage (Use group C / CSA)	150 V
Rated current (Use group B / CSA)	65 A
Rated current (Use group D / CSA)	10 A
Wire cross-section, AWG, max.	AWG 6

**Rated data acc. to UL 1059**

Institute (UR)



Certificate No. (UR)

E60693

Rated voltage (Use group B / UL 1059)	300 V
Rated voltage (Use group D / UL 1059)	600 V
Rated current (Use group C / UL 1059)	65 A
Wire cross-section, AWG, min.	AWG 26
Reference to approval values	Specifications are maximum values, details - see approval certificate.

Rated voltage (Use group C / UL 1059)	150 V
Rated current (Use group B / UL 1059)	65 A
Rated current (Use group D / UL 1059)	5 A
Wire cross-section, AWG, max.	AWG 6

**Packing**

Packaging	Box	VPE length	140 mm
VPE width	105 mm	VPE height	40 mm

**Type tests**

Test: Durability of markings	Test	mark of origin, type identification, type of material, rated cross-section, approval marking CSA, approval marking UL, pitch, durability
	Evaluation	available

**LU 10.16/03/90 4STI 3.2SN GY BX**

**Weidmüller Interfaces GmbH & Co. KG**

Postfach 3030

32760 Detmold

Tel. +49 5231 14-0

Fax. +49 5231 14-2083

**Technische Daten**

Test: Clampable cross section	Conductor type	Type of conductor and conductor cross-section	H05V-K0.5 www.weidmuller.com	
		Type of conductor and conductor cross-section	H05V-U0.5 www.weidmuller.com	
		Type of conductor and conductor cross-section	H07V-K10	
		Type of conductor and conductor cross-section	H07V-U10	
		Type of conductor and conductor cross-section	H07V-U16	
		Type of conductor and conductor cross-section	AWG 8/19	
		Type of conductor and conductor cross-section	AWG 22/1	
		Type of conductor and conductor cross-section	AWG 22/19	
		Evaluation	passed	
Test for damage to and accidental loosening of conductors	Standard	EN 60947-1/1991 section 8.2.4.3		
	Requirement	0.3 kg		
	Conductor type	Type of conductor and conductor cross-section	H05V-K0.5	
		Type of conductor and conductor cross-section	H05V-U0.5	
		Type of conductor and conductor cross-section	AWG 22/1	
		Type of conductor and conductor cross-section	AWG 22/19	
	Evaluation	passed		
	Requirement	2.0 kg		
	Conductor type	Type of conductor and conductor cross-section	H07V-K10	
		Type of conductor and conductor cross-section	H07V-U10	
		Type of conductor and conductor cross-section	AWG 8/19	
	Evaluation	passed		
	Requirement	2.9 kg		
Conductor type	Type of conductor and conductor cross-section	H07V-U16		
Evaluation	passed			

## LU 10.16/03/90 4STI 3.2SN GY BX

Weidmüller Interfaces GmbH & Co. KG

Postfach 3030

32760 Detmold

Tel. +49 5231 14-0

## Technische Daten

Fax. +49 5231 14-2083

Pull-out test	Standard	EN 60947-1/1991 section 8.2.4.4
	Requirement	≥20 N info@weidmueller.com
Conductor type	Type of conductor and conductor cross-section	AWG 22/1
	Type of conductor and conductor cross-section	AWG 22/19
Evaluation	passed	
Requirement	≥30 N	
Conductor type	Type of conductor and conductor cross-section	H05V-K0.5
	Type of conductor and conductor cross-section	H05V-U0.5
Evaluation	passed	
Requirement	≥ 90N	
Conductor type	Type of conductor and conductor cross-section	H07V-K10
	Type of conductor and conductor cross-section	H07V-U10
	Type of conductor and conductor cross-section	AWG 8/19
Evaluation	passed	
Requirement	≥100 N	
Conductor type	Type of conductor and conductor cross-section	H07V-U16
Evaluation	passed	

### Classifications

ETIM 6.0	EC002643	ETIM 7.0	EC002643
ETIM 8.0	EC002643	ECLASS 9.0	27-44-04-01
ECLASS 9.1	27-44-04-01	ECLASS 10.0	27-44-04-01
ECLASS 11.0	27-46-01-01	ECLASS 12.0	27-46-01-01

### Important note

IPC conformity Conformity: The products are developed, manufactured and delivered according international recognized standards and norms and comply with the assured properties in the data sheet resp. fulfill decorative properties in accordance with IPC-A-610 "Class 2". Further claims on the products can be evaluated on request.

- Notes
- Additional variants on request
  - Rated current related to rated cross-section & min. No. of poles.
  - Wire end ferrule without plastic collar to DIN 46228/1
  - Wire end ferrule with plastic collar to DIN 46228/4
  - P on drawing = pitch
  - Rated data refer only to the component itself. Clearance and creepage distances to other components are to be designed in accordance with the relevant application standards.
  - Long term storage of the product with average temperature of 50 °C and average humidity 70%, 36 months

Erstellungs-Datum May 30, 2023 2:19:09 PM CEST

Katalogstand 26.05.2023 / Technische Änderungen vorbehalten

**LU 10.16/03/90 4STI 3.2SN GY BX**

**Weidmüller Interfaces GmbH & Co. KG**

Postfach 3030

32760 Detmold

Tel. +49 5231 14-0

Fax. +49 5231 14-2083

[info@weidmueller.com](mailto:info@weidmueller.com)

[www.weidmueller.com](http://www.weidmueller.com)

## Technische Daten

### Approvals

Approvals



ROHS	Conform
UL File Number Search	UL Website
Certificate No. (UR)	E60693

### Downloads

Engineering Data	<a href="#">WSCAD</a>
Product Change Notification	<a href="#">20220201 Visual change OMNIMATE® Power PCB terminal blocks and connectors</a> <a href="#">20220201 Visuelle Änderung OMNIMATE® Power Leiterplattenklemmen und -steckverbinder</a>
User Documentation	<a href="#">QR-Code product handling video</a>
Catalogues	<a href="#">Catalogues in PDF-format</a>
Brochures	<a href="#">FL DRIVES EN</a> <a href="#">MB DEVICE MANUF. EN</a> <a href="#">FL DRIVES DE</a> <a href="#">FL APPL INVERTER EN</a> <a href="#">FL BASE STATION EN</a> <a href="#">FL ELEVATOR EN</a> <a href="#">FL POWER SUPPLY EN</a> <a href="#">FL 72H SAMPLE SER EN</a> <a href="#">PO OMNIMATE EN</a>

**LU 10.16/03/90 4STI 3.2SN GY BX**

**Weidmüller Interfaces GmbH & Co. KG**

Postfach 3030

32760 Detmold

Tel. +49 5231 14-0

Fax. +49 5231 14-2083

**Zeichnungen**

**Dimensional drawing** [info@weidmueller.com](mailto:info@weidmueller.com)

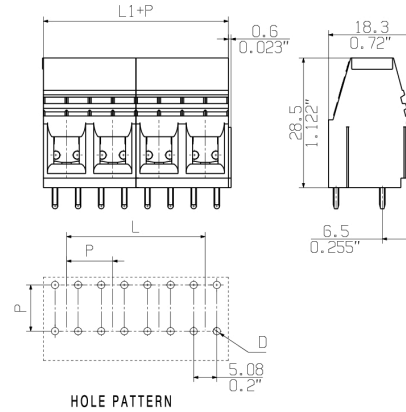

**Graph**

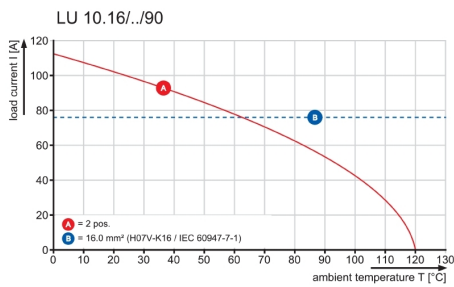



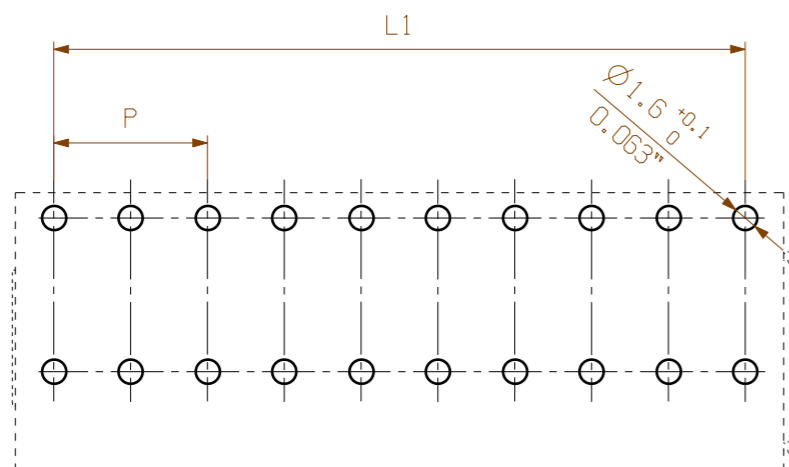
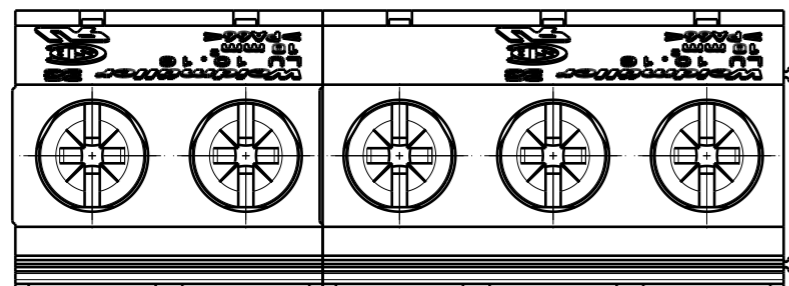
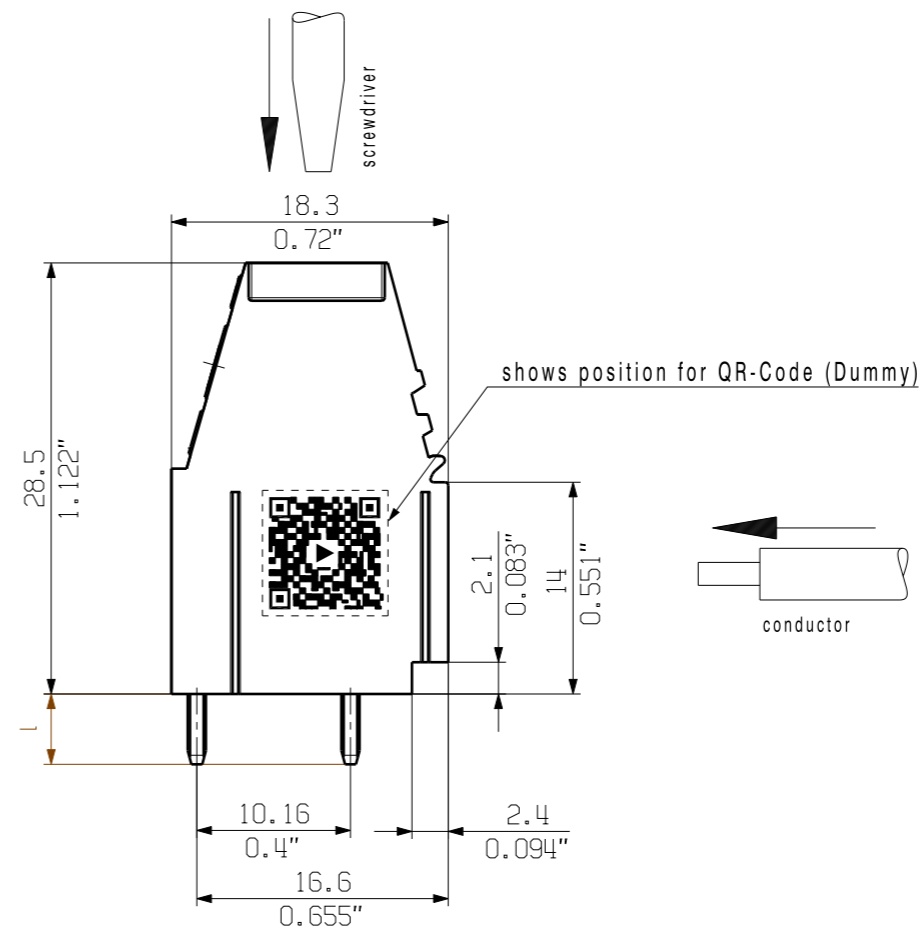
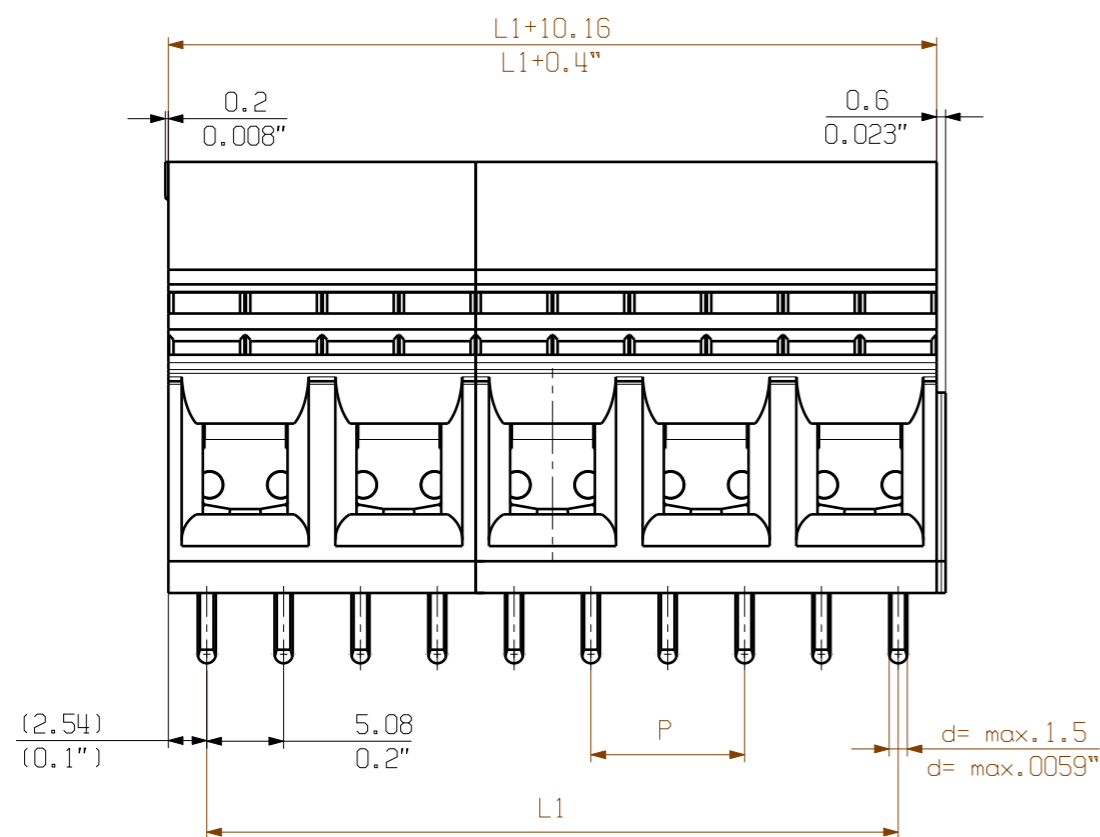

shown : LU 10.16/05/90

l = solder pin length (4.5/3.2)

P = pitch (10.16)

n = no of poles

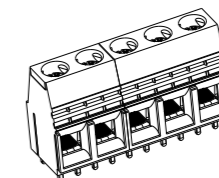

12	116,84	4,600
11	106,68	4,200
10	96,52	3,800
9	86,36	3,400
8	76,20	3,000
7	66,04	2,600
6	55,88	2,200
5	45,72	1,800
4	35,56	1,400
3	25,40	1,000
2	15,24	0,600
<b>n</b>	<b>L1[mm]</b>	<b>L1 [Inch]</b>

For the mounting of PCBs, it should be noted that the rated data relates only to the PCB components alone. The necessary creepage and clearance paths must be observed in connection with the respective applicant in accordance to IEC 664 / VDE 0110. The current-carrying capacity and pitch tolerance is to be determined according to DIN IEC 326 part 3 very fine.

Weidmüller PCB components are tested to the DIN EN 61984 standard, and are valid for its field of application. Provided that the components are used to the intended purpose, all requirements with respect to the occurring of electrical, mechanical, thermic and corrosive stress will be satisfied.

<b>GENERAL TOLERANCE:</b> DIN ISO 2768-mK 	102098	04	Prim PLM Part No.: 017733	Prim ERP Part No.: 1635920000
	First Issue Date 16.02.2018			<b>21310</b> Drawing no. Issue no. 10 Sheet 01 of 01 sheets
	Date 16.02.2018 Name Administrator	Date 12.11.2018 Name Lang, Thomas	<b>LU 10.16/././90</b> LEITERPLATTENKLEMME PCB TERMINAL	
Scale: 2:1      Size: A3 Drawings Assembly	Approved		Product file: 7232 LU 10.16	

## Recommended wave soldering profiles

**Weidmüller Interface GmbH & Co. KG**  
 Klingenbergstraße 16  
 D-32758 Detmold  
 Germany  
 Fon: +49 5231 14-0  
 Fax: +49 5231 14-292083  
 www.weidmueller.com

### Single Wave:



### Double Wave:



### Wave soldering profiles

Wired connection elements should be processed in accordance with the DIN EN 61760-1 standard. We have included two recommendations for practical wave soldering profiles, with which Weidmüller PCB terminals and connectors are qualified.

When choosing a suitable profile for your application, the following factors also need to be considered:

- PCB thickness
- Proportion of Cu in the layers
- Single/double-sided assembly
- Product range
- Heating and cooling rates

The single and double wave profiles each indicate the recommended operating range, including the maximum soldering temperature of 260°C. In practice, the maximum soldering temperature is quite often well below the above maximum profile.