

HDC HDD 108 MC 109-216**Weidmüller Interface GmbH & Co. KG**

Klingenbergstraße 26

D-32758 Detmold

Germany

www.weidmueller.com



The HDD series with machined crimp contacts is designed for high pole counts in tight spaces. Thanks to the smaller design, you can save installation space during without having to limit the number of poles.

The wire connection level is designed for crimp contacts.

The proven crimp connection method has been in standard use for decades. Crimp contacts are not included in the scope of delivery of inserts.

Crimp connection

General ordering data

| | |
|------------|--|
| Version | HDC insert, Male, 250 V, 10 A, Number of poles: 108, Crimp connection, Size: 8 |
| Order No. | 1651280000 |
| Type | HDC HDD 108 MC 109-216 |
| GTIN (EAN) | 4008 190299880 |
| Qty. | 1 pc(s). |

Creation date February 23, 2023 1:15:20 PM CET

Catalogue status 18.02.2023 / We reserve the right to make technical changes.

HDC HDD 108 MC 109-216**Weidmüller Interface GmbH & Co. KG**

Klingenbergstraße 26

D-32758 Detmold

Germany

www.weidmueller.com

Technical data**Dimensions and weights**

| | | | |
|------------|--------|-----------------|------------|
| Depth | 111 mm | Depth (inches) | 4.37 inch |
| Height | 35 mm | Height (inches) | 1.378 inch |
| Width | 34 mm | Width (inches) | 1.339 inch |
| Net weight | 68 g | | |

Temperatures

| | |
|-------------------|-------------------|
| Limit temperature | -40 °C ... 125 °C |
|-------------------|-------------------|

Dimensions

| | | | |
|----------------|-------|-------------------|--------|
| Height of plug | 35 mm | Total length base | 111 mm |
| Width | 34 mm | | |

General data

| | | | |
|------------------------------|---|--------------------------------------|---------------------|
| BG | 8 | Conductor cross-section | 2.5 mm ² |
| Insulating material | PC glass-fibre reinforced (UL-listed and railway-certified) | Insulating material group | IIIa |
| Insulation strength | 10 ¹⁰ Ω | Material | Copper alloy |
| Number of poles | 108 | Plugging cycles, gold | ≥ 500 |
| Plugging cycles, silver | ≥ 500 | Pollution severity | 3 |
| Rated current (DIN EN 61984) | 10 A | Rated impulse voltage (DIN EN 61984) | 4 kV |
| Rated voltage (DIN EN 61984) | 250 V | Rated voltage according to UL/CSA | 600 V AC/DC |
| Series | HDD | Size | 8 |
| Type | Male | UL 94 flammability rating | V-0 |
| Volume resistance | ≤4 mΩ | | |

Connection data PE

| | | | |
|---------------------------------------|----------------------------|---------------------------------------|---------------------|
| Blade size, slotted (PE connection) | SD 0.6 x 3.5, SD 0.8 x 4.0 | Connection type PE | Screw connection |
| Fixing screw | M 4 | Rated cross-section | 2.5 mm ² |
| Stripping length PE connection | 10 mm | Tightening torque, max. PE connection | 1.5 Nm |
| Tightening torque, min. PE connection | 1.2 Nm | Wire cross section, AWG (PE), max. | AWG 14 |
| Wire cross section, AWG (PE), min. | AWG 20 | | |

Version

| | | | |
|---|----------------------|---|----------------------|
| BG | 8 | Conductor cross-section, max. | 2.05 mm ² |
| Conductor cross-section, min. | 0.14 mm ² | Material | Copper alloy |
| Size | 8 | Stripping length, rated connection | 8 mm |
| Type of connection | Crimp connection | Volume resistance | ≤4 mΩ |
| Wire connection cross section AWG, max. | AWG 14 | Wire connection cross section AWG, min. | AWG 26 |
| Wire connection cross section, finely stranded, max. | 2.5 mm ² | Wire connection cross section, finely stranded, min. | 0.5 mm ² |
| Wire connection cross-section, finely stranded with wire-end ferrules DIN 46228/4, max. | 2.5 mm ² | Wire connection cross-section, finely stranded with wire-end ferrules DIN 46228/4, min. | 0.5 mm ² |
| Wire cross-section, solid, max. | 2.5 mm ² | Wire cross-section, solid, min. | 0.5 mm ² |

HDC HDD 108 MC 109-216

Weidmüller Interface GmbH & Co. KG

Klingenbergstraße 26

D-32758 Detmold

Germany

www.weidmueller.com

Technical data

Classifications

| | | | |
|-------------|-------------|-------------|-------------|
| ETIM 6.0 | EC000438 | ETIM 7.0 | EC000438 |
| ETIM 8.0 | EC000438 | ECLASS 9.0 | 27-44-02-05 |
| ECLASS 9.1 | 27-44-02-05 | ECLASS 10.0 | 27-44-02-05 |
| ECLASS 11.0 | 27-44-02-05 | ECLASS 12.0 | 27-44-02-05 |

| | |
|---------------------|---------------------------|
| Substance | Acetone |
| Chemical resistance | Resistant |
| Substance | Ammonia, watery |
| Chemical resistance | Conditionally resistant |
| Substance | Petrol |
| Chemical resistance | Resistant |
| Substance | Benzene |
| Chemical resistance | Resistant |
| Substance | Diesel oil |
| Chemical resistance | Conditionally resistant |
| Substance | Acetic acid, concentrated |
| Chemical resistance | Resistant |
| Substance | Potassium hydroxide |
| Chemical resistance | Conditionally resistant |
| Substance | Methanol |
| Chemical resistance | Conditionally resistant |
| Substance | Motor oil |
| Chemical resistance | Conditionally resistant |
| Substance | Lye, diluted |
| Chemical resistance | Resistant |
| Substance | Hydrochlorofluorocarbons |
| Chemical resistance | Conditionally resistant |
| Substance | Outdoor use |
| Chemical resistance | Conditionally resistant |

Environmental Product Compliance

| | |
|---------------------|---|
| REACH SVHC | Potassium perfluorobutane sulfonate 29420-49-3 |
| SCIP | 1609748e-c278-4c9b-b3d1-e6215d2988cd |
| Chemical resistance | de.myview.objectmodel.impl.BlockImpl@5ebae2ec de.myview.objectmodel.impl.BlockImpl@31032253 de.myview.objectmodel.impl.BlockImpl@afaedd2 de.myview.objectmodel.impl.BlockImpl@28e2cea6 de.myview.objectmodel.impl.BlockImpl@21c6e4d4 de.myview.objectmodel.impl.BlockImpl@9ff5b05 de.myview.objectmodel.impl.BlockImpl@5436a395 de.myview.objectmodel.impl.BlockImpl@6a9fd04b de.myview.objectmodel.impl.BlockImpl@7ce96988 de.myview.objectmodel.impl.BlockImpl@fbd3263 de.myview.objectmodel.impl.BlockImpl@6ef6120a de.myview.objectmodel.impl.BlockImpl@7aff8a17 |

HDC HDD 108 MC 109-216

Weidmüller Interface GmbH & Co. KG
Klingenbergstraße 26
D-32758 Detmold
Germany

www.weidmueller.com

Technical data

Approvals

Approvals



ROHS

Conform

Downloads

Approval/Certificate/Document of
Conformity

[Manufacturer's declaration](#)

Engineering Data

[CAD data – STEP](#)

Engineering Data

[WSCAD](#)

Catalogues

[Catalogues in PDF-format](#)

Brochures

[FL FIELDWIRING EN](#)
[FL FIELDWIRING EN](#)

HDC HDD 108 MC 109-216

Weidmüller Interface GmbH & Co. KG
Klingenbergstraße 26
D-32758 Detmold
Germany

www.weidmueller.com

Drawings

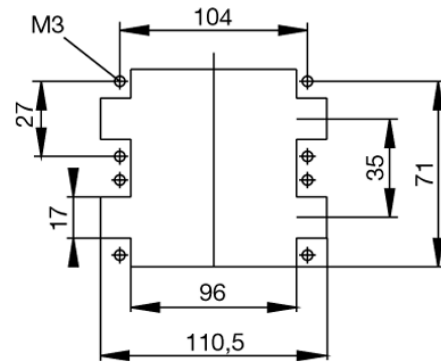
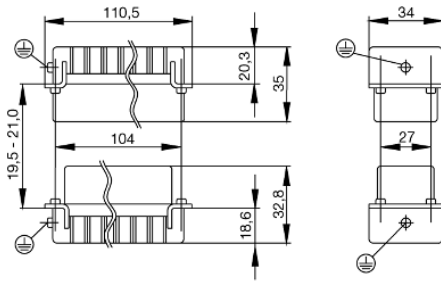

Tightening torques and screwing tools

| Screw size | Connector type | Dia. tightening torque in Nm | Recommended blade inserts and AF size for hexagon socket | |
|--------------------------------|---|---|--|-----------------------------------|
| M 2.5 | Signal contacts | | | |
| | S 6/6 | 0.5 - 0.55 | SD 0.6 x 3.5 mm or PZ0 | |
| | S 6/12 | 0.5 - 0.55 | SD 0.6 x 3.5 mm or PZ0 | |
| M 2.9 x 0.5 | Fastening screws | | | |
| | HQ 4/2 | 0.8 (plastic) / 1.1 (metal) | SD 0.6 x 3.5 mm or PH0 | |
| | HQ 8 | 0.8 (plastic) / 1.1 (metal) | SD 0.6 x 3.5 mm or PH0 | |
| | HQ 17 | 0.8 (plastic) / 1.1 (metal) | SD 0.6 x 3.5 mm or PH0 | |
| M 3 | Contact screws | | | |
| | HA 3 | 0.5 - 0.55 | SD 0.5 x 3.0 mm | |
| | HA 4 | 0.5 - 0.55 | SD 0.5 x 3.0 mm | |
| | HA 10 bis HA 48 | 0.5 - 0.55 | SD 0.6 x 3.5 mm or PH0 | |
| | HE | 0.5 - 0.55 | SD 0.6 x 3.5 mm or PZ0 | |
| | HVE | 0.5 - 0.55 | SD 0.6 x 3.5 mm or PZ0 | |
| | Signal contacts: | | | |
| | S 4/2 | 0.5 - 0.55 | SD 0.6 x 3.5 mm or PZ0 | |
| | S 4/8 | 0.5 - 0.55 | SD 0.6 x 3.5 mm or PZ0 | |
| | PE connection via female contact | | | |
| | S 4 | 0.5 - 0.8 | SD 0.6 x 3.5 mm | |
| | ConCept modular frame, metal | 0.5 - 0.55 | SD 0.6 x 3.5 mm | |
| | PE terminal | | | |
| | HQ 5 | 0.5 - 0.55 | SD 0.6 x 3.5 or 0.8 x 4 mm | |
| | HQ 7 | 0.5 - 0.55 | SD 0.6 x 3.5 or 0.8 x 4 mm | |
| | Fastening screws | 0.5 - 0.55 | SD 0.6 x 3.5 mm or PZ0 | |
| | Guide pin | 0.5 - 0.55 | SD 0.6 x 3.5 mm or PZ0 | |
| | Guide bush | 0.5 - 0.55 | SD 0.6 x 3.5 mm or PZ0 | |
| | Coding pins | 0.5 - 0.55 | SD 0.6 x 3.5 mm or PZ0 | |
| | M 4 | Contact screws | | |
| | | HSB | 1.2 - 1.5 | SD 0.6 x 3.5 or 0.8 x 4 mm or PZ1 |
| | | PE connection via male contact | | |
| S 4 | | 0.5 - 0.8 | SD 0.6 x 3.5 mm | |
| ConCept modular frame, metal | | 1.2 - 1.5 | SD 0.6 x 3.5 mm | |
| PE terminal | | | | |
| HA | | 1.2 - 1.5 | SD 0.6 x 3.5 or 0.8 x 4 mm or PH1 | |
| HE | | 1.2 - 1.5 | SD 0.6 x 3.5 or 0.8 x 4 mm or PH1 | |
| HEE | | 1.2 - 1.5 | SD 0.6 x 3.5 or 0.8 x 4 mm or PH1 | |
| HVE | | 1.2 - 1.5 | SD 0.6 x 3.5 or 0.8 x 4 mm or PH1 | |
| HD | | 1.2 - 1.5 | SD 0.6 x 3.5 or 0.8 x 4 mm or PZ1 | |
| HDD | | 1.2 - 1.5 | SD 0.6 x 3.5 or 0.8 x 4 mm or PZ1 | |
| S 6/6 (for signal contacts) | | 1.2 - 1.5 | 0.8 x 4 mm or PZ1 | |
| ConCept modular frame, plastic | | 1.2 - 1.5 | 0.8 x 4 mm or PZ1 | |
| M 5 | | PE terminal | | |
| | | HSB | 2 - 2.5 | SD 1 x 5.5 mm or PZ2 |
| | | S 4/0 (Screw connection) | 2 - 2.5 | SD 1.2 x 6.5 mm or PH2 |
| | S 4/0 (Axial screw connection) | 2 - 2.5 | SD 0.8 x 4 mm or PZ 2 | |
| | S 4/2 | 2 - 2.5 | SD 1.2 x 6.5 mm or PH2 | |
| | S 4/8 | 2 - 2.5 | SD 1.2 x 6.5 mm or PH2 | |
| | S 6/12 | 2 - 2.5 | SD 0.8 x 4 mm or PZ 2 | |
| | S 6/36 | 2 - 2.5 | SD 1.2 x 6.5 mm or PH2 | |
| | S 8/24 | 2 - 2.5 | SD 1.2 x 6.5 mm or PH2 | |
| | S 12/2 | 2 - 2.5 | SD 1.2 x 6.5 mm or PH2 | |
| | M 6 | Power contacts | | |
| S 4/0 (Screw connection) | | 1.2 (1.5 mm ²) / 2 (2.5 mm ²) / 3 (4-16 mm ²) | SD 0.8 x 4 mm | |
| S 4/2 | | 1.2 (1.5 mm ²) / 2 (2.5 mm ²) / 3 (4-16 mm ²) | SD 0.8 x 4 mm | |
| S 4/8 | | 1.2 (1.5 mm ²) / 2 (2.5 mm ²) / 3 (4-16 mm ²) | SD 0.8 x 4 mm | |
| M 7 x 0.75 | Power contacts | | | |
| | S 4 | 1.1 - 1.7 | SW 2 | |
| | S 6/6 (+ PE) | 6 - 8 | SW 4 | |
| M 8 x 0.75 | Power contacts | | | |
| | S 6/12 | 1.1 - 1.7 | SW 2 | |
| | S 8/0 (+ PE) | 6 (10-16 mm ²) - 7 (25 mm ²) | SW 4 | |
| M10 x 1 | Power contacts | | | |
| | S 4/0 (Axial connection) | 2 - 3 | SW 3 | |

Increasing the tightening torque does not improve the contact resistance. The stated torque settings offer optimal mechanical, thermal and electrical conditions. Exceeding the recommended values may even damage the conductor and terminal.