

**LHZ-SMT R 1.5SN BK RL**

**Weidmüller Interfaces GmbH & Co. KG**

Postfach 3030

32760 Detmold

Tel. +49 5231 14-0

Fax. +49 5231 14-2083

info@weidmueller.com

www.weidmueller.com

**Product image**

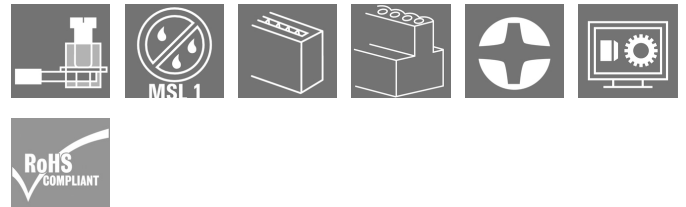

**Naturally, the CH20M system also shows its detailed perfection in the peripheral interface.**

If you are taking into consideration design options, processing, usability, reliability and security, then pin headers and connectors are just as critical in the real world as the entire system.

In every sector, the connection technology is at the top of its class.

- **100% safe** protected against accidental touch
- **100% efficient** fully compatible with reflow soldering
- **100% time and cost savings** During the installation: the quick all-purpose "Multi-Tool" screw head ensures a secure contact, user-friendly operation and less complexity. Additional features, such as the "Wire ready" technology, enable you to minimize wiring costs and increase customer satisfaction.

**General ordering data**

Version	Printed circuit board terminals, Connection element, right, block assembly, closed side, THT/THR solder connection, Number of poles: 1, Solder pin length (l): 1.5 mm, tinned, black, Tape
Order No.	<a href="#">2418590000</a>
Type	LHZ-SMT R 1.5SN BK RL
GTIN (EAN)	4032248984343
Qty.	432 Stück
Product data	IEC: 500 V / 0.2 - 2.5 mm <sup>2</sup> UL: 300 V / 10 A / AWG 26 - AWG 14
Packaging	Tape

## LHZ-SMT R 1.5SN BK RL

Weidmüller Interfaces GmbH & Co. KG

Postfach 3030

32760 Detmold

Tel. +49 5231 14-0

Fax. +49 5231 14-2083

info@weidmueller.com

www.weidmueller.com

## Technische Daten

### Dimensions and weights

Depth	23.49 mm	Depth (inches)	0.925 inch
Height	16.98 mm	Height (inches)	0.669 inch
Width	6 mm	Width (inches)	0.236 inch
Length	23.5 mm	Length (inches)	0.925 inch
Net weight	3.306 g		

### Temperatures

Operating temperature, min.	-40 °C	Operating temperature, max.	120 °C
Continuous operating temp., max.	120 °C		

### System Parameters

Product family	OMNIMATE Housing - series CH20M6	Type of connection	Clamping yoke connection
Wire connection method	Clamping yoke connection	Conductor outlet direction	90°
Number of poles	1	Number of rows	1
Pin series quantity	1	Protection degree	IP20
Stripping length	6 mm	Tightening torque, min.	0.4 Nm
Tightening torque, max.	0.5 Nm	Clamping screw	M 3
Screwdriver blade	0.6 x 3.5	Screwdriver blade standard	DIN 5264

### Material data

Insulating material	LCP	Colour	black
Colour chart (similar)	RAL 9011	Insulating material group	IIIa
Comparative Tracking Index (CTI)	175 ≤ CTI < 400	Moisture Level (MSL)	1
UL 94 flammability rating	V-0	Contact surface	tinned
Storage temperature, min.	-40 °C	Storage temperature, max.	70 °C
Operating temperature, min.	-40 °C	Operating temperature, max.	120 °C
Temperature range, installation, min.	-25 °C	Temperature range, installation, max.	120 °C

### Conductors suitable for connection

Clamping range, min.	0.13 mm <sup>2</sup>	Clamping range, max.	2.5 mm <sup>2</sup>
Wire connection cross section AWG, min.	AWG 26	Wire connection cross section AWG, max.	AWG 14
Solid, min. H05(07) V-U	0.2 mm <sup>2</sup>	Solid, max. H05(07) V-U	2.5 mm <sup>2</sup>
Flexible, min. H05(07) V-K	0.2 mm <sup>2</sup>	Flexible, max. H05(07) V-K	2.5 mm <sup>2</sup>
w. plastic collar ferrule, DIN 46228 pt 4, min.	0.25 mm <sup>2</sup>	w. plastic collar ferrule, DIN 46228 pt 4, max.	2.5 mm <sup>2</sup>
w. wire end ferrule, DIN 46228 pt 1, min.	0.2 mm <sup>2</sup>	Reference text	Length of ferrules is to be chosen depending on the product and the rated voltage., The outside diameter of the plastic collar should not be larger than the pitch (P)

## LHZ-SMT R 1.5SN BK RL

Weidmüller Interfaces GmbH & Co. KG

Postfach 3030

32760 Detmold

Tel. +49 5231 14-0

Fax. +49 5231 14-2083

info@weidmueller.com

www.weidmueller.com

## Technische Daten

### Rated data acc. to IEC

tested acc. to standard	IEC 60664-1, IEC 61984	Rated current, max. number of poles (Tu=20°C)	13 A
Rated current, max. number of poles (Tu=40°C)	13 A	Rated voltage for surge voltage class / pollution degree II/2	500 V
Rated voltage for surge voltage class / pollution degree III/2	320 V	Rated voltage for surge voltage class / pollution degree III/3	250 V
Rated impulse voltage for surge voltage class/ pollution degree II/2	4 kV	Rated impulse voltage for surge voltage class/ pollution degree III/2	4 kV
Rated impulse voltage for surge voltage class/ contamination degree III/3	4 kV		

### Rated data acc. to CSA

Rated voltage (Use group B / CSA)	300 V	Rated voltage (Use group D / CSA)	300 V
Rated current (Use group B / CSA)	10 A	Rated current (Use group D / CSA)	10 A
Wire cross-section, AWG, min.	AWG 26	Wire cross-section, AWG, max.	AWG 14

### Rated data acc. to UL 1059

Institute (cURus)		Certificate No. (cURus)	E60693
Rated voltage (Use group B / UL 1059)	300 V	Rated voltage (Use group D / UL 1059)	300 V
Rated current (Use group B / UL 1059)	10 A	Rated current (Use group D / UL 1059)	10 A
Wire cross-section, AWG, min.	AWG 26	Wire cross-section, AWG, max.	AWG 14
Clearance distance, min.	1.6 mm	Creepage distance, min.	2.4 mm
Reference to approval values	Specifications are maximum values, details - see approval certificate.		

### General data

Colour	black	Colour chart (similar)	RAL 9011
Protection degree	IP20		

### Material data

Comparative Tracking Index (CTI)	175 ≤ CTI < 400	Insulating material	LCP
Insulating material group	IIIa	UL 94 flammability rating	V-0

### Classifications

ETIM 6.0	EC002643	ETIM 7.0	EC002643
ETIM 8.0	EC002643	ECLASS 9.0	27-44-04-01
ECLASS 9.1	27-44-04-01	ECLASS 10.0	27-44-04-01
ECLASS 11.0	27-46-01-01	ECLASS 12.0	27-46-01-01

### Important note

IPC conformity Conformity: The products are developed, manufactured and delivered according international recognized standards and norms and comply with the assured properties in the data sheet resp. fulfill decorative properties in accordance with IPC-A-610 "Class 2". Further claims on the products can be evaluated on request.

## LHZ-SMT R 1.5SN BK RL

Weidmüller Interfaces GmbH & Co. KG

Postfach 3030

32760 Detmold

Tel. +49 5231 14-0

Fax. +49 5231 14-2083

[info@weidmueller.com](mailto:info@weidmueller.com)

[www.weidmueller.com](http://www.weidmueller.com)

## Technische Daten

### Approvals

Approvals



ROHS	Conform
UL File Number Search	UL Website
Certificate No. (cURus)	E60693

### Downloads

Engineering Data	<a href="#">CAD data – PCB Reference Layout</a> <a href="#">CAD data – STEP</a>
Engineering Data	<a href="#">WSCAD, EPLAN</a>
Catalogues	<a href="#">Catalogues in PDF-format</a>
Brochures	<a href="#">FL ANALO.SIGN.CONV. EN</a> <a href="#">MB DEVICE MANUF. EN</a> <a href="#">FL MACHINE SAFETY EN</a> <a href="#">FL 72H SAMPLE SER EN</a> <a href="#">PO OMNIMATE EN</a> <a href="#">PO OMNIMATE EN</a>

**LHZ-SMT R 1.5SN BK RL**

**Weidmüller Interfaces GmbH & Co. KG**

Postfach 3030

32760 Detmold

Tel. +49 5231 14-0

Fax. +49 5231 14-2083

[info@weidmueller.com](mailto:info@weidmueller.com)

[www.weidmueller.com](http://www.weidmueller.com)

**Zeichnungen**

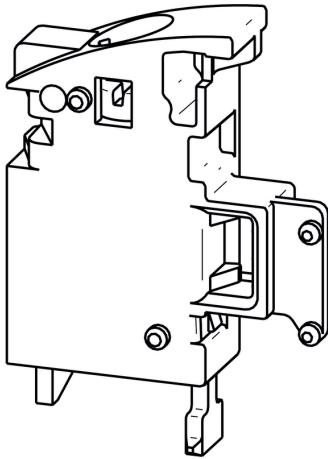

**Example of use**



## Recommended reflow soldering profile

**Weidmüller Interface GmbH & Co. KG**  
 Klingenbergstraße 16  
 D-32758 Detmold  
 Germany  
 Fon: +49 5231 14-0  
 Fax: +49 5231 14-292083  
 www.weidmueller.com



### Reflow soldering profile

The perfect soldering profile for SMT Surface Mount Technology is one the most exiting question in SMT production. But there are more than one correct answer: The diagram of temperature-on-time is related to processing features of solder paste and to maximum load of components.

We have to consider the following parameters:

- Time for pre heating
- Maximum temperature
- Time above melting point
- Time for cooling
- Maximum heating rate
- Maximum cooling rate

We recommend a typical solder profile with associated process limits. With preheating components and board are prepared smoothly for the solder phase. Heating rate is typically  $\leq +3\text{K/s}$ . In parallel the solder paste is ‚activated‘. The time above melting point of 217°C the paste gets liquid and components and boards begin to connect. The maximum temperature of 245°C to 254°C should stay between 10 and 40 seconds. In the cooling phase at  $\geq -6\text{K/s}$  solder is cured. Board and components cool down while avoiding cold cracks.

## Recommended wave soldering profiles

**Weidmüller Interface GmbH & Co. KG**  
 Klängenbergstraße 16  
 D-32758 Detmold  
 Germany  
 Fon: +49 5231 14-0  
 Fax: +49 5231 14-292083  
 www.weidmueller.com

### Single Wave:



### Double Wave:

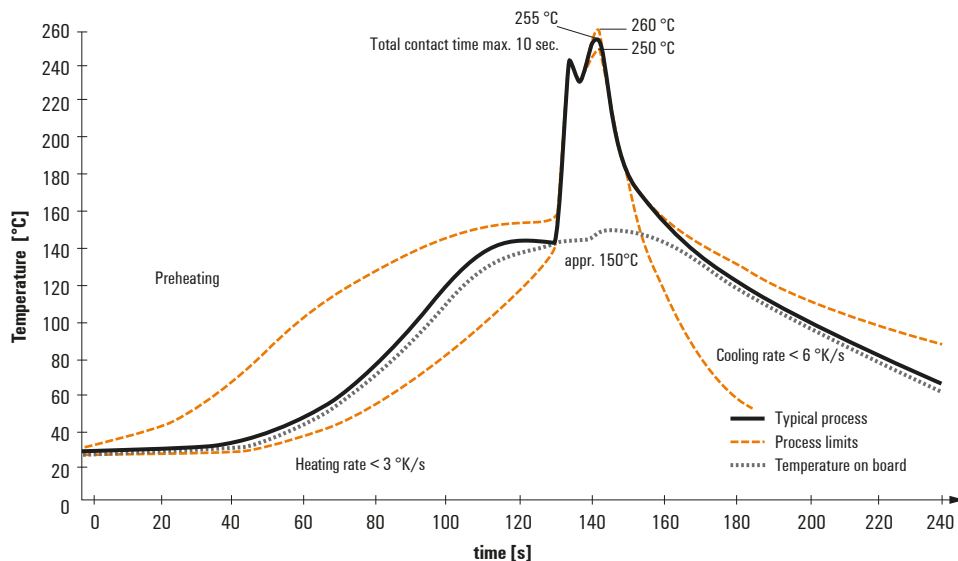

### Wave soldering profiles

Wired connection elements should be processed in accordance with the DIN EN 61760-1 standard. We have included two recommendations for practical wave soldering profiles, with which Weidmüller PCB terminals and connectors are qualified.

When choosing a suitable profile for your application, the following factors also need to be considered:

- PCB thickness
- Proportion of Cu in the layers
- Single/double-sided assembly
- Product range
- Heating and cooling rates

The single and double wave profiles each indicate the recommended operating range, including the maximum soldering temperature of 260°C. In practice, the maximum soldering temperature is quite often well below the above maximum profile.