

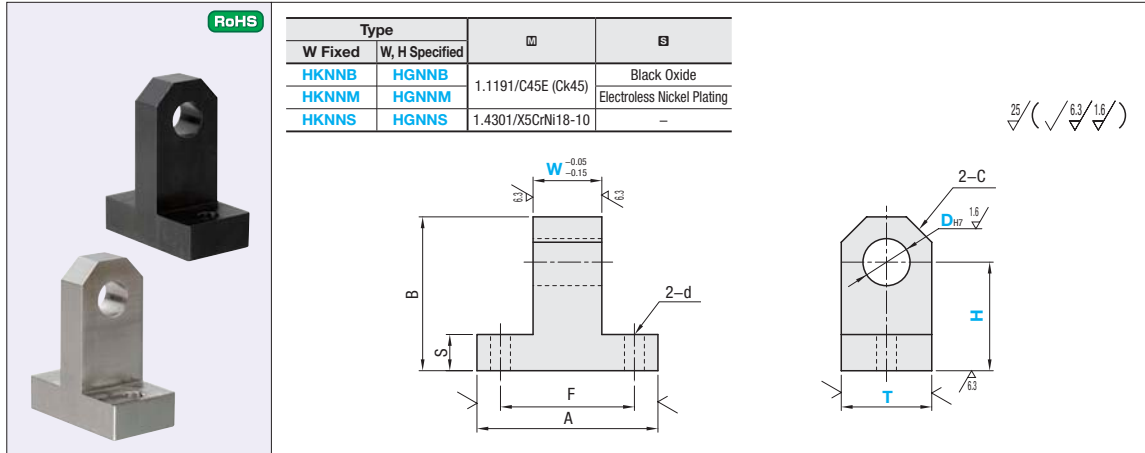

Thick Hinge Bases

-T-Shaped Type-

CAD Data



Type		□	⊖
W Fixed	W, H Specified		
HKNNB	HGNNB	1.1191/C45E (Ck45)	Black Oxide
HKNNM	HGNNM		Electroless Nickel Plating
HKNS	HGNS	1.4301/X5CrNi18-10	-

Part Number	Type	DH7	T Selection	W			A	F	B	S	d	C	Unit Price Qty. 1~4					
				Fixed	1mm Increment	1mm Increment							W Dimension Fixed			W, H Dimension Specified		
													HKNNB	HKNNM	HKNS	HGNNB	HGNNM	HGNS
4	12	8	3~8	17~25	25	17	H + (T/2)	5	4.5	10	5.5	3	21,40	23,70	31,00	23,50	25,70	33,00
5	16	8	5~12	18~30	32	23						4	23,40	25,70	33,80	25,40	27,80	35,80
6	19	8	5~12	18~30	32	23						5	25,00	27,40	36,00	27,00	29,40	38,00
8	22	10	8~16	26~35	38	28						6	27,10	29,80	39,50	29,10	31,80	41,50
10	25	10	8~16	26~35	38	28						7	30,60	33,40	43,90	32,60	35,40	45,90
12	28	10	10~18	28~40	50	37						8	35,20	38,70	50,90	37,20	40,70	52,90
14	30	12	12~24	36~45	50	37						9	44,00	43,90	59,60	42,00	46,00	61,60
16	32	16	12~24	36~45	50	37						10	44,90	49,20	73,20	46,90	51,30	75,20
20	38	20	20~35	45~55	65	49						11	44,90	49,20	73,20	46,90	51,30	75,20
25	38	30	20~35	45~55	65	49						11	44,90	49,20	73,20	46,90	51,30	75,20

Order Example: Part Number - T - W - H
 HKNNB10 - T22 - W25 - H35
 HGNNM20 - T38 - W25 - H48

Days to Ship: 8 Days
 • HKNNB · HKNS

Price Volume Discount P.92

Quantity	1~4	5~9	10~19
Rate	Price List	5%	10%

*For orders larger than indicated values, please request for quotation.

Other Than Those Above
 10 Days Express B 5,00 EUR/ piece P.92

Ⓢ An Express Charge of 13.50 EUR for 3 or more identical pieces.
 Ⓢ Express Service is not available for HKNNM and HGNNM.

List of Diameter (DH7), Thickness (T) and Thickness on one side

DH7	Hinge Base Standard Type (P.1817~P.1824)		Hinge Base Thick Type		
	T	Thickness on one side (T-DH7)/2	T	Thickness on one side (T-DH7)/2	T
4	9	2.5	12	4	-
5	12	3.5	16	5.5	7
6	12	3	16	5	19
8	16	4	19	5.5	22
10	16	3	19	4.5	6
12	19	3.5	22	5	6.5
13	19	3	22	4.5	6
14	19	4	22	5.5	8
15	22	3.5	25	5	7.5
16	22	3	25	4.5	7
20	25	2.5	30	5	38
25	30	2.5	38	6.5	-

Alterations

Part Number - T - W - H - (WDC)
 HKNNB10 - T22 - W25 - H35 - WDC

Alteration	Code	Spec.	Price Adder
	WDC	Changes the number of d holes from 2 to 4. The holes are drilled at T1 position. Ordering Code WDC T T1 16 8 19 10 22 12 25 14 30 15 38 20	3,00

Ⓢ Not available for D4.

1813 Features: (1) The hole's thickness on one side is selectable by working load. (2) New products can specify H and W dimensions in 1mm increment.



Thick Hinge Bases

-Concave Shaped Type-

CAD Data

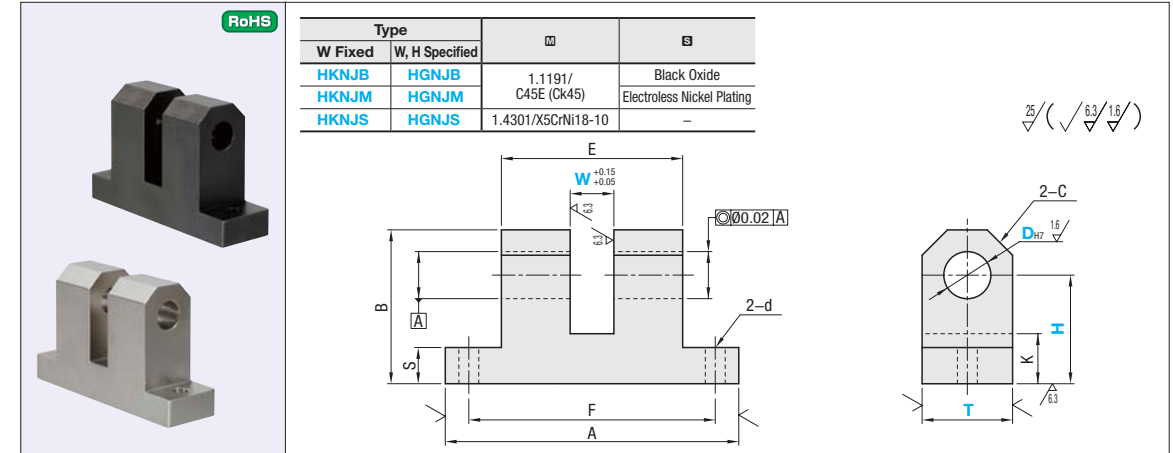

Type		□	⊖
W Fixed	W, H Specified		
HKNJB	HGNJB	1.1191/C45E (Ck45)	Black Oxide
HKNJM	HGNJM		Electroless Nickel Plating
HKNJS	HGNJS	1.4301/X5CrNi18-10	-

Part Number	Type	DH7	T Selection	W			A	F	B	E	K	S	d	C	Unit Price Qty. 1~4						
				Fixed	1mm Increment	1mm Increment									W Dimension Fixed			W, H Dimension Specified			
															HKNJB	HKNJM	HKNJS	HGNJB	HGNJM	HGNJS	
4	12	8	4~12	17~25	38	29	H + (T/2)	50	20	10	5	4.5	10	5.5	3	27,40	30,20	39,90	29,40	32,20	41,90
5	16	8	5~15	21~30	50	41									4	30,50	33,60	45,50	32,50	35,70	47,60
6	19	8	5~15	21~30	50	41									5	32,20	35,40	48,10	34,30	37,40	50,20
8	22	10	8~24	25~35	65	52									6	34,20	37,40	52,60	36,30	39,40	54,60
10	25	10	8~24	25~35	65	52									7	36,50	40,10	56,50	38,60	42,10	58,50
12	28	12	10~30	27~40	75	62									8	38,50	42,10	60,10	40,50	44,10	62,10
14	30	14	10~30	27~40	75	62									9	39,10	43,00	59,20	41,10	45,00	61,20
16	32	16	10~30	27~40	75	62									10	42,50	46,40	64,40	44,60	48,40	66,40
20	38	20	20~35	35~50	100	82									11	48,30	53,10	72,60	50,30	55,10	74,60
25	38	30	20~35	35~50	100	82									11	48,30	53,10	72,60	50,30	55,10	74,60

Order Example: Part Number - T - W - H
 HKNJB6 - T19 - W25 - H27
 HGNJM20 - T38 - W25 - H48

Days to Ship: 8 Days
 • HKNJB · HKNJS

Price Volume Discount P.92

Quantity	1~4	5~9	10~19
Rate	Price List	5%	10%

*For orders larger than indicated values, please request for quotation.

Other Than Those Above
 10 Days Express B 5,00 EUR/ piece P.92

Ⓢ An Express Charge of 13.50 EUR for 3 or more identical pieces.
 Ⓢ Express Service is not available for HKNJM and HGNJM.

List of Diameter (DH7), Thickness (T) and Thickness on one side

DH7	Hinge Base Standard Type (P.1817~P.1824)		Hinge Base Thick Type		
	T	Thickness on one side (T-DH7)/2	T	Thickness on one side (T-DH7)/2	T
4	9	2.5	12	4	-
5	12	3.5	16	5.5	7
6	12	3	16	5	19
8	16	4	19	5.5	22
10	16	3	19	4.5	6
12	19	3.5	22	5	6.5
13	19	3	22	4.5	6
14	19	4	22	5.5	8
15	22	3.5	25	5	7.5
16	22	3	25	4.5	7
20	25	2.5	30	5	38
25	30	2.5	38	6.5	-

Alterations

Part Number - T - W - H - (WDC)
 HKNJB6 - T19 - W25 - H27 - WDC

Alteration	Code	Spec.	Price Adder
	WDC	Changes the number of d holes from 2 to 4. The holes are drilled at T1 position. Ordering Code WDC T T1 16 8 19 10 22 12 25 14 30 15 38 20	3,00

Ⓢ Not available for D4.

1814 Features: (1) The hole's thickness on one side is selectable by working load. (2) New products can specify H and W dimensions in 1mm increment.