

Bushings for Miniature Ball Guides

Standard / Compact

= For customers using industry standard products =
 The part enclosed in the red frame is as per industry standard specifications (EN 1.3505 Equiv. material, Straight Bushings).
 Select from the specifications here.

Features: Most common type of bushings for miniature ball guides.

Industry Standard



Type		Material		Hardness	
Standard	Compact	Material	Hardness	Material	Hardness
BGB	BGH	EN 1.3505 Equiv.	58HRC~	EN 1.3505 Equiv.	58HRC~
SSBGB	SSBGH	EN 1.4125 Equiv.	56HRC~	EN 1.4125 Equiv.	56HRC~

RoHS 10

Use Ball Slider Compact Type (BYS) in combination with Compact Type; Ball Sliders Standard Type (BGS, SSBGS) with Standard Type.
 Loctite is recommended to fix bushings.

Standard

BGB SSBGB

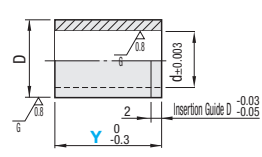

BGH SSBGH

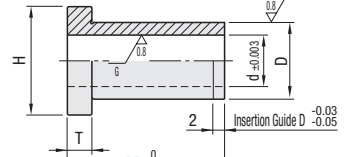

Compact

Straight BYB

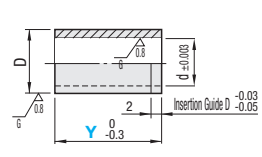

Shouldered BYH

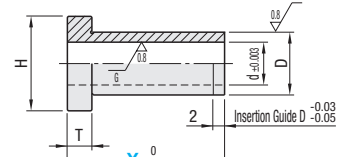

Standard

Part Number Type	No.	Y Selection	D O.D. Tolerance	T	H	d	W	B	D1	Unit Price			
										BGB	SSBGB	BGH	SSBGH
BGB	3	10	7	2.5	9	5	-	-	-				
		20											
		30											
	4	10	8	3	10	6	-	-	-				
		20											
		30											
	5	10	10	3	12	7	-	-	-	9.6			
		20											
		30											
	6	20	11	4	13	8	1.1	-	-	10.5			
		30											
		40											
8	20	12	4	14	10	1.1	-	-	11.5				
	30												
	40												
10	30	16	4	18	12	-	-	-	15.2				
	40												
	50												
12	30	18	4	20	14	1.3	-	-	17				
	40												
	50												

Ordering Example: Part Number - Y
 BYB5 - 20
 BGS5 - 20
 BGH10 - 40

Compact

Part Number Type	No.	Y Selection	D O.D. Tolerance	T	H	d	Unit Price			
							BYB	SSBYB	BYH	SSBYH
BYB	2	10 15 20	5	2.5	7	3.2				
		10 20								
	3	30	6	3	8	4.2				
		10 20								
	4	30	7	3	9	5.2				
		10 20								
	5	30	8	3	10	6.2				
		10 20								
	6	20 30 40	9	4	11	7.2				
		20 30 40								
	8	20 30 40	11	4	13	9.2				
		20 30 40								
10	30 40	14	4	16	12					
	30 40									
12	30 40	16	4	18	14					
	30 40									

Bushings for Miniature Ball Guides / Ball Sliders

Compact / Standard

Features: The flanges can be screw mounted for convenient assembly.

Flanged

BGHT (Mounting Hole)

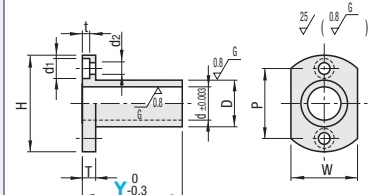

Material: EN 1.3505 Equiv.
 Hardness: 58HRC ~

RoHS 10

Part Number Type	No.	Y Selection	D O.D. Tolerance	H	W	P	T	d	d1	d2	t	Unit Price	
BGHT	5	20	10	25	16	17	7	6	3.5	2.2			
		30											
	6	20 30 40	12	28	18	20	4	8					
		20 30 40											
	8	20 30 40	14	29	20	21	5	10					
		20 30 40											
10	30 40	16	34	22	25	5	12	7.5	4.5	3			
	30 40												
12	30 40	19	40	25	29	5	14						
	30 40												

Use in combination with Ball Sliders Standard Type (BGS, SSBGS).

Features: Most common specification in ball sliders for miniature ball guides.

Ball Sliders - Standard

Type	Material	Material	Hardness
	Ball Retainer	Balls	Balls
BGS	EN CW614N Equiv. (RoHS Compliant)	EN 1.3505 Equiv.	58HRC~
SSBGS	EN CW614N Equiv. (RoHS Compliant)	EN 1.4125 Equiv.	56HRC~

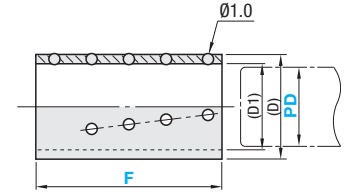

RoHS 10

Part Number Type	PD	F Selection	(D)	(D1)	Unit Price	
					BGS	SSBGS
BGS	3	10 15 20	4.8	3.2		
					10 15 20	
	4	15 20 30	5.8	4.2		
					15 20 30	
	5	20 30 40	6.8	5.2		
					20 30 40	
6	30 40	7.8	6.2			
				30 40		
8	40 50	9.8	8.2			
				40 50		
10	50 60	11.8	10.2			
				50 60		
12	60 70	13.8	12.2			
				60 70		

Use in combination with Bushings for Miniature Ball Guides Standard Type (BGB, SSBGB, BGH, SSBGH, BGHT).
 Basic Load Rating P_{361}

= For customers using industry standard products =
 The part enclosed in the red frame is as per industry standard specifications.
 Select from the specifications here.

Features: As compared to the Standard Type, O.D. (D dimension) is 1mm compact.

Ball Sliders - Compact

Type	Material	Material	Hardness
	Ball Retainer	Balls	Balls
BYS	EN CW614N Equiv. (RoHS Compliant)	EN 1.3505 Equiv.	58HRC~

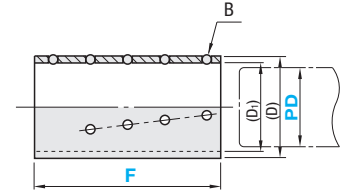

RoHS 10

Part Number Type	PD	F Selection	(D)	(D1)	B	Unit Price
BYS	2	10 15 20	3.1	2.1	0.6	
						10 15 20
	3	15 20 30	4.1	3.1	0.6	
						15 20 30
	4	20 30 40	5.1	4.1	0.6	
						20 30 40
5	30 40	6.1	5.1	0.6		
					30 40	
6	40 50	7.1	6.1	0.6		
					40 50	
8	50 60	9.1	8.1	0.6		
					50 60	
10	60 70	11.8	10.2	1.0		
					60 70	
12	70 80	13.8	12.2	1.0		
					70 80	

Use in combination with Bushings for Miniature Ball Guides Compact Type (BYB, BYH).
 Basic Load Rating P_{361}

Ordering Example: Part Number - Y, F
 BGHT5 - 20
 BGS5 - 15