

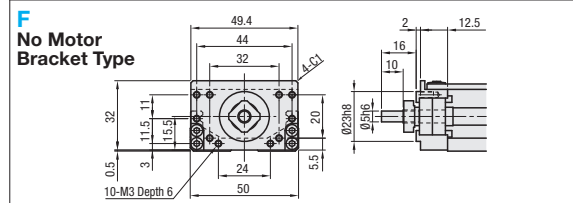

### Motor Adapter Plate Dimensional Drawing

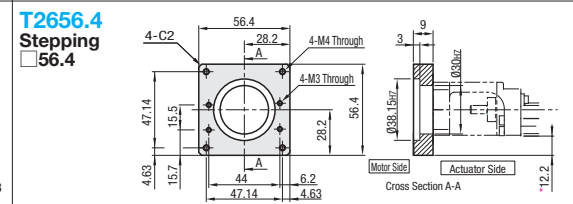
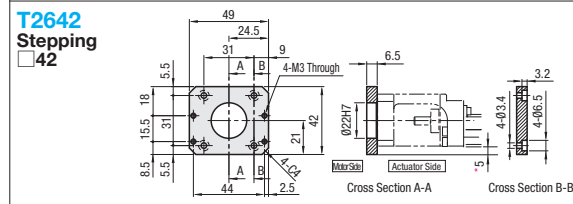
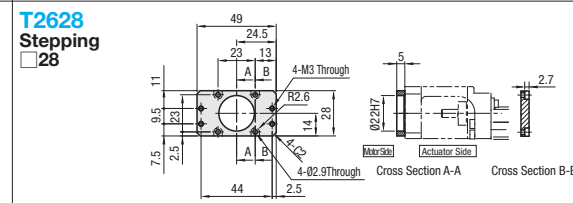
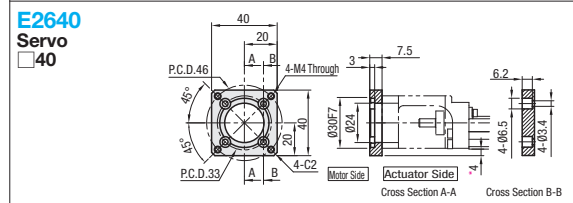
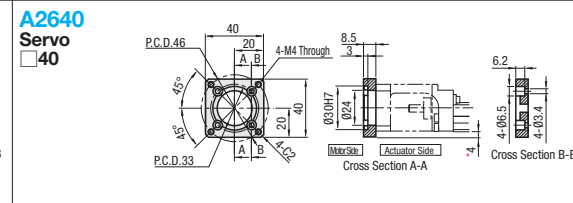
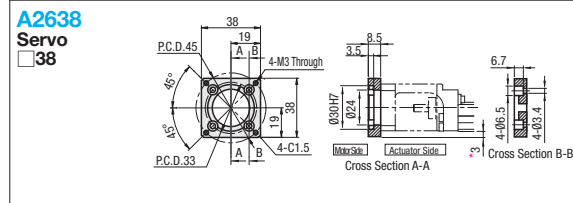
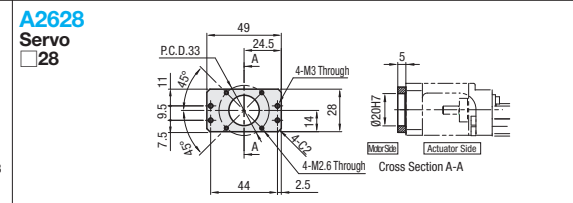
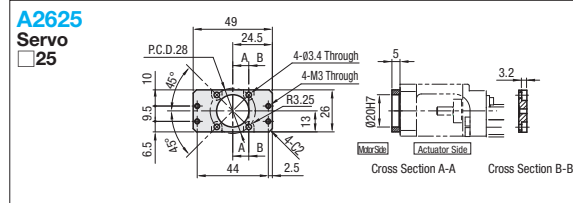

### Servo Motor Application Table

Part Number	Flange Size	Manufacturer	Product Number	Wattage	Recommended Coupling
A2625	□25	Yasukawa Electric Corporation	SGMMJ-A1	10W	SCXW21 (P1076) SCPW21 (P1076) CPDW19 (P1075)
			SGMMJ-A2	20W	
			SGMMJ-A3	30W	
A2628	□28	Mitsubishi Electric Corporation	HG-AK0136	10W	
			HG-AK0236	20W	
			HG-AK0336	30W	
A2638	□38	Panasonic	MSMD5A	50W	
			MSME5A	100W	
			MSMD01*		
A2640	□40	Yasukawa Electric Corporation	SGMJV-A5	50W	
			SGMAH-A5		
			SGMAS-A5		
			Mitsubishi Electric Corporation	HG-MR053	30W
				HG-KR053	
				HF-KP053	
			Sanyo Denki Co., Ltd.	O1AA04003D	50W
				O1AA04005D	
			Omron Corporation	R88M-K05030	50W
				MV-M05	
Keyence Corporation	SV-M005	100W			
	1FK7011-5				
E2640	□40	SIEMENS	1FK7015-5	100W	
			1FK7015-5		

### Stepping Motor Application Table

Part Number	Flange Size	Manufacturer	Product Number	Type	Recommended Coupling
T2628	□28	Oriental Motor	CSK22	2-phase	SCXW21 (P1076) SCPW21 (P1076) CPDW19 (P1075)
			CSK52	5-phase	
			ASC3*	αStep	
T2642	□42	Oriental Motor	AR2 (ARM)	2-phase	
			PK24*	αStep	
			CSK24	2-phase	
T2656.4	□56.4	NEMA standards	RK54	5-phase	
			RKS54* / PK54*	αStep	
			AS46, ASC46, AR46	αStep	

\* Shaft insertion depth on coupling will be 0.5mm shorter on each side when used with Siemens motor.  
 \* Product numbers and specifications of motors are subject to change. Please check the manufacturers' information.  
 \* Applicable motors and couplings are not limited to the above listed products. Please confirm each mounting dimension.

⚠ NEMA standards is a set of standards stipulated by National Electrical Manufacturers Association of United States.  
 ⚠ Not compatible with geared motors made by Oriental Motor.

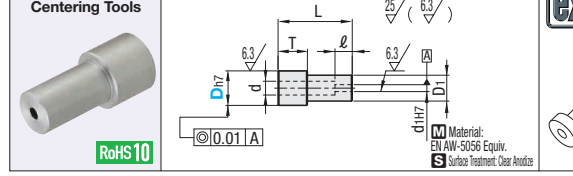

Part Number	D	Applicable Adapter Plate	d	D1	d1	L	T	ℓ	Unit Price 1 - 5 pcs.
JIGLX26	20	A2628	8	15	5	47.5	17	12	
	30	A2638/A2640/T2656.4	8	15	5	49.5	13	11	

Note: Note that the Motor Adapter protrudes beyond the rail at \* marked area.

### Proximity Sensor (SUNX) - Set Part Specification

LX Part Number	Code	Sensor Type/Qty.	Sensor Rail		Sensor (* Qty per Sensor Included)		Sensor Flag		Unit Price (L≤200)			Unit Price (L≥250)					
			Rail (1 pc.)	Mounting Screw (Pitch +1 pc.)	Sensor Bracket	Bracket Mounting Screw Nut	Sensor Mounting Screw	Sensor Mounting Washer	Sensor Flag (1 pc.)	Sensor Flag Mounting Screw	1 pc.	2 pcs.	3 pcs.	1 pc.	2 pcs.	3 pcs.	
LX26□□	XA	□ pc(s).															
LX26□□C	XB	□ pc(s).															
LX26□□	FA	□ pc(s).															
LX26□□	FB	□ pc(s).															
LX26□□	XW1	1 pc.	SENAT3□H	SCB3-6	Dedicated	SCB3-5 (2 pcs.) LBNR3 (2 pcs.)	SCB3-6 (2 pcs.)	M2 Small Flat Washer (2 pcs.)	Dedicated	Flat Head Machine Screw M2.6-4 (1 pc.)							
LX26□□C	XW2	2 pcs.								SCB3-6 (2 pcs.)							
LX26□□C	FW1	1 pc.															
LX26□□C	FW2	2 pcs.															

### Photo Sensor (SUNX) - Set Part Specification

LX Part Number	Code	Photo Sensor	Sensor Rail		Sensor (* Qty per Sensor Included)			Sensor Flag		Unit Price (L≤200)			Unit Price (L≥250)				
			Rail (1 pc.)	Mounting Screw (Pitch +1 pc.)	Sensor Bracket	Bracket Mounting Screw Nut	Sensor Mounting Screw	Sensor Mounting Washer	Sensor Flag (1 pc.)	Sensor Flag Mounting Screw	1 pc.	2 pcs.	3 pcs.	1 pc.	2 pcs.	3 pcs.	
LX26□□	SP	PM-L25	SENAT3□H	SCB3-6	Dedicated	SCB3-5 (2 pcs.) LBNR3 (2 pcs.)	SCB3-6 (2 pcs.)	M2 Small Flat Washer (2 pcs.)	Dedicated	Flat Head Machine Screw M2.6-4 (1 pc.)							
LX26□□C	MP									SCB3-5 (2 pcs.)							

⚠ The Photo Sensor PM-L24 is to be discontinued and replaced by the next-generation product PM-L25 in April 2017.

### Photo Sensor (Omron) - Set Part Specification

LX Part Number	Code	Photo Sensor	Sensor Rail		Sensor (* Qty per Sensor Included)			Sensor Flag		Unit Price (L≤200)			Unit Price (L≥250)				
			Rail (1 pc.)	Mounting Screw (Pitch +1 pc.)	Sensor Bracket	Bracket Mounting Screw Nut	Sensor Mounting Screw	Sensor Mounting Washer	Sensor Flag (1 pc.)	Sensor Flag Mounting Screw	1 pc.	2 pcs.	3 pcs.	1 pc.	2 pcs.	3 pcs.	
LX26□□	OP	EE-SX911-R1M	SENAT3□H	SCB3-6	Dedicated	SCB3-5 (2 pcs.) LBNR3 (2 pcs.)	SCB3-6 (2 pcs.)	Small Flat Washer (2 pcs.)	Dedicated	Flat Head Machine Screw M2.6-4 (1 pc.)							
LX26□□C	EP									SCB3-6 (2 pcs.)							

\* Sensors are not sold separately.  
 ⚠ EE-SX911-R1M is scheduled to change to EE-SX951-R1M from April 2015.

Alterations

Part Number - Block Qty. - Motor Adapter Plates - Base Length (L) - (Code)

LX2602 - B1 - A2628 - 300 - XW1

LX2605C - B1 - A2638 - 200 - MP2

### Proximity Sensor Type Installation Drawings - SUNX

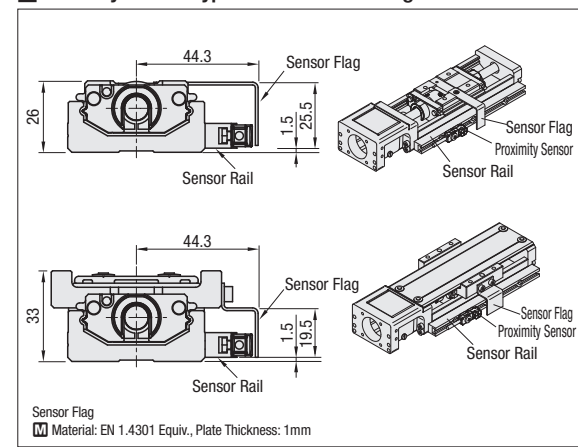

### Photo Sensor Type Installation Drawings - SUNX / Omron

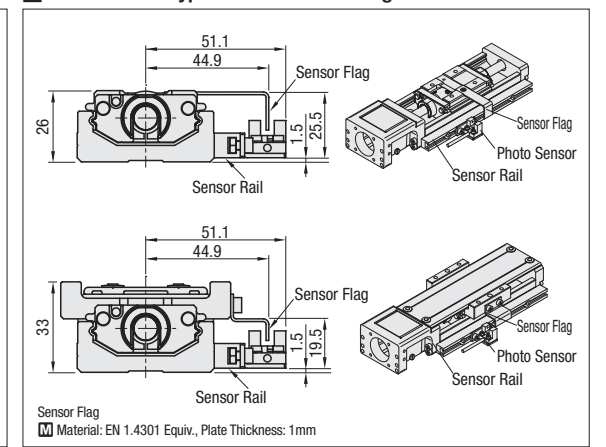

**Cautions**

- Sensor set is shipped with LX Actuator. Assembly required.
- Please check for all included parts immediately after unpacking. Some small parts can be lost.
- Please handle the products with great care.

⚠ Please access each sensor manufacturer's website for the specifications of sensors in use.