



Cam Followers

Hex Socket on Head / Thread (Flat Type with Grease Fitting)

■ Flat



RoHS 10

Application	Type		Material	Accessory
	With Seal	No Seal		
General	CFFH	CFAH	EN 1.3505 Equiv.1	Hex Nut (EN 1.1191 Equiv. Carbon Steel, Black Oxide)
	CFFSH	CFASH	EN 1.4125 Equiv.	Hex Nut 1 pc. (EN 1.4301 Equiv.)
Low Dust Generation	CFFCH	-	-	-
Heavy Load	CFFGH	-	EN 1.3505 Equiv.1	Hex Nut (EN 1.1191 Equiv. Carbon Steel, Black Oxide)

■ With Seal

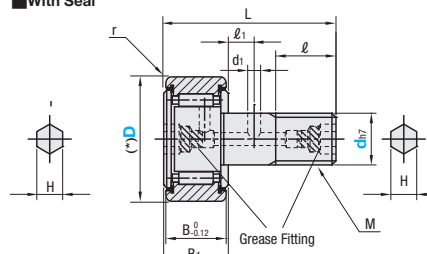

■ No Seal

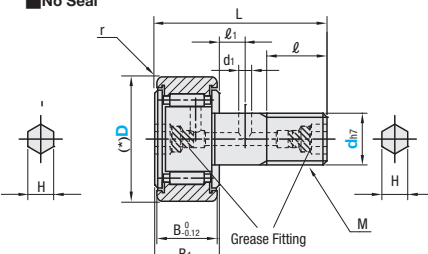

D	Tolerance
30	-0.009
32-47	-0.011
52-80	-0.013
80-90	-0.015

(*) Operating Temp.: 80°C or lower

Part Number		D (Selectable)	MxPitch	B	B ₁	L	d ₁	ℓ	ℓ ₁	r	f (Min.)	H	Mass (g)	Max. Tightening Torque (N • cm)	Unit Price						
Type	dh7 Tolerance														CFFH	CFFSH	CFFCH	CFFGH	CFAH	CFASH	
(With Seal) CFFH CFFSH CFFCH CFFGH	12	30	12x1.5	14	15	40	3	14	6	1.5	20	6	105(107)	29.4							
		32											115(117)								
	16	35	16x1.5	18	19.5	52	3	18	8	1.5	24	6	205(207)	70.6							
		40											295(300)								
	20	47	20x1.5	24	25.5	66	4	22	9	1.5	36	6	450(455)	137							
		52											525(530)								
	(No Seal) CFAH CFASH	24	62	24x1.5	29	30.5	80	4	25	11	1.5	40	8	915(925)	245						
			72											1150(1160)							
	30	0 -0.021	80	30x1.5	35	37	100	4	32	15	2	46	8	1880(1890)	480						
			85											1950(1960)							
90			2000(2010)																		

For the performance of Cam Followers, see Table 1 on P.1043.

Ordering Example: Part Number **CFFH20** - D **52**

Part Number Substitution Table for Cam Follower Standard Changes (D30-40,52 only)

Type	Old Part Number (D30-40,52)			New Part Number
	Old Standard	Old Hex Socket Type	Old Hex Socket on Thread	Hex Socket on Head and Thread
Cam Followers	CFUR	CFUA	CFUB	CFUH
	CFURS	CFUAS	-	CFUSH
	CFURC	CFUAC	-	CFUCH
	-	CFUAG	-	CFUGH
	CFU	CUA	-	CUH
	CFUS	CUAS	-	CUSH
	CFFR	CFFA	CFFB	CFFH
	CFFRS	CFFAS	-	CFFSH
	CFFRC	CFFAC	-	CFFCH
	-	CFFAG	-	CFFGH
	CFR	CFA	-	CFAH
	CFRS	CFAS	-	CFASH