

Resin Roller Conveyor Length Configurable

Roller Diameter 20mm, 30mm, 50mm Type

■Features: Light weight (approx. 2.3kg/m) Roller Conveyor composed of resin rollers and aluminum frame.



Type	① Roller (HRJA)	Bearing	② Frame	
	M Material	M Material	M Material	S Surface Treatment
ROCO P	ABS Plastic	Outer Wheel / Inner Wheel : Polyacetal Retainer : Nylon 66 Cover : ABS Plastic Ball : EN 1.4301 Equiv.	Aluminum	Clear Anodize

Type	R Pin		Frame Coupling Support		Screw, Nut	
	M Material	S Surface Treatment	M Material	S Surface Treatment	M Material	S Surface Treatment
ROCO P	Steel	Trivalent Chromate	Steel	Trivalent Chromate	Steel	Trivalent Chromate

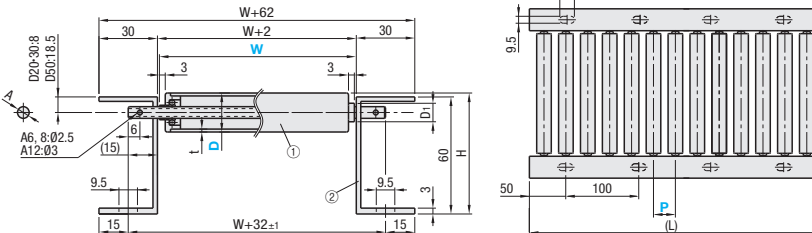

Ⓜ For Alterations, see P.1170. Ⓜ For Frame Side View, see P.1166.
 Ⓜ If the L dimension is 400 or less, there are 2 holes with a pitch of 100, with the holes spaced equally from the center.
 Ⓜ If the L dimension is 150 or less, there are no stand mounting holes.

Part Number Type	D	Number of Rollers	W (Roller Width)	P (Pitch)	A	D ₁	t	H	Roller Strength for Reference (N)					
									W113	W213	W313	W413	W513	
									D20	D30	D50			
ROCO P	20	5~40	113	25	6	9.5	1.5	62	113	105	98	90	83	
	30	5~32	213	40	8	14	1.8	67	162	154	147	139	132	
	50	5~13	413	75	12	17	2.8	66.5	314	304	294	289	279	

■Roller Diameter 20, 30mm Type

Part Number Type	Number of Rollers	L	Unit Price 1 ~ 5 pc(s).													
			D20		D30		W113		W213		W313		W413		W513	
			P=25	P=40	P=50	P=25	P=40	P=50	P=25	P=40	P=50	P=25	P=40	P=50	P=25	P=40
	5	(120)	(195)	(245)												
	6	(145)	(235)	(295)												
	7	(170)	(275)	(345)												
	8	(195)	(315)	(395)												
	9	(220)	(355)	(445)												
	10	(245)	(395)	(495)												
	11	(270)	(435)	(545)												
	12	(295)	(475)	(595)												
	13	(320)	(515)	(645)												
	14	(345)	(555)	(695)												
	15	(370)	(595)	(745)												
	16	(395)	(635)	(795)												
	17	(420)	(675)	(845)												
	18	(445)	(715)	(895)												
	19	(470)	(755)	(945)												
	20	(495)	(795)	(995)												
	21	(520)	(835)	(1045)												
	22	(545)	(875)	(1095)												
	23	(570)	(915)	(1145)												
	24	(595)	(955)	(1195)												
	25	(620)	(995)	(1245)												
	26	(645)	(1035)	(1295)												
	27	(670)	(1075)	-												
	28	(695)	(1115)	-												
	29	(720)	(1155)	-												
	30	(745)	(1195)	-												
	31	(770)	(1235)	-												
	32	(795)	(1275)	-												
	33	(820)	-	-												
	34	(845)	-	-												
	35	(870)	-	-												
	36	(895)	-	-												
	37	(920)	-	-												
	38	(945)	-	-												
	39	(970)	-	-												
	40	(995)	-	-												

Ⓜ Reference roller strength is per single roller. Ⓜ For orders larger than indicated quantity, please check with WOS.

■Roller Diameter 50mm Type

Part Number Type	Number of Rollers	L	Unit Price 1 ~ 5 pc(s).											
			D50		W113		W213		W313		W413		W513	
			P=75	P=100	P=75	P=100	P=75	P=100	P=75	P=100	P=75	P=100		
	5	(370)	(495)											
	6	(445)	(595)											
	7	(520)	(695)											
	8	(595)	(795)											
	9	(670)	(895)											
	10	(745)	(995)											
	11	(820)	(1095)											
	12	(895)	(1195)											
	13	(970)	(1295)											

Ⓜ For orders larger than indicated quantity, please check with WOS.

Ordering Example: Part Number - Number of Rollers - W - P
 ROCOP20 - 10 - 213 - 25

Alterations P.1170

Roller Conveyor Length Configurable

Roller 19mm Diameter Type

■Features: Short roller conveyors 1m or less, with configurable width and length.

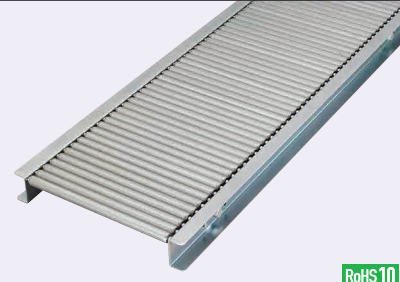

Roller Pitch	① Roller (HRO19)	Bearing	② Frame	
	M Material	S Surface Treatment	M Material	S Surface Treatment
ROCO P=20	Steel	Trivalent Chromate	Steel	Trivalent Chromate
ROCON P=30	Steel	Trivalent Chromate	Steel	Trivalent Chromate

Roller Pitch	R Pin	Frame Coupling Support	Screw, Nut	
	M Material	S Surface Treatment	M Material	S Surface Treatment
ROCO P=20	Steel	Trivalent Chromate	Steel	Trivalent Chromate
ROCON P=30	Steel	Trivalent Chromate	Steel	Trivalent Chromate

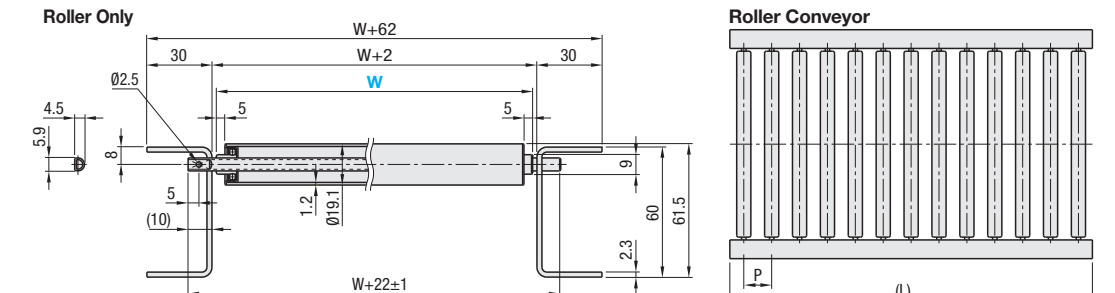

Ⓜ For Alterations, see P.1170. Ⓜ For Frame Side View, see P.1166.

Part Number Type	Number of Rollers	L	Unit Price													
			ROCO P=20	ROCON P=30	ROCO (P=20)				ROCON (P=30)							
			W113	W213	W313	W413	W513	W113	W213	W313	W413	W513				
	6	(120)	(190)													
	7	(140)	(200)													
	8	(160)	(230)													
	9	(180)	(260)													
	10	(200)	(290)													
	11	(220)	(330)													
	12	(240)	(360)													
	13	(260)	(390)													
	14	(280)	(430)													
	15	(300)	(460)													
	16	(320)	(490)													
	17	(340)	(500)													
	18	(360)	(530)													
	19	(380)	(560)													
	20	(400)	(590)													
	21	(420)	(630)													
	22	(440)	(660)													
	23	(460)	(690)													
	24	(480)	(730)													
	25	(500)	(760)													
	26	(520)	(790)													
	27	(540)	(800)													
	28	(560)	(830)													
	29	(580)	(860)													
	30	(600)	(890)													
	31	(620)	(930)													
	32	(640)	-													
	33	(660)	-													
	34	(680)	-													
	35	(700)	-													
	36	(720)	-													
	37	(740)	-													
	38	(760)	-													
	39	(780)	-													
	40	(800)	-													
	41	(820)	-													
	42	(840)	-													
	43	(860)	-													
	44	(880)	-													
	45	(900)	-													
	46	(920)	-													
	47	(940)	-													
	48	(960)	-													

Ordering Example: Part Number - W
 ROCO38 - 113
 ROCON22 - 313

Alterations P.1170