

# Motor Type

Dedicated web site <http://fa.misumi.jp/cvs/>  
 Conveyor selecting, component purchases, and easy search for maintenance parts are available.

## Motor Manufacturer A (Panasonic Motor) Motor Type

	Induction Motor	Variable Speed Motor
Model		
Features	Motor suitable for continuous one-way operation.	Motor that the speed can be infinitely variable by combining with a Speed Controller
Voltage	Single-phase 230V	Single-phase 230V
Continuous Operation	○	○
Instantaneous Reverse Operation	×	×
Variable Speed	×	○
Load Holding	×	×

Output	6W, 25W, 40W, 60W, 90W
Rated Voltage	230V
Voltage Range	±10% (In relation to Rated Voltage)*
Power Supply Frequency	50Hz
Speed Control Range	90~1400min <sup>-1</sup> (50Hz)
Speed Fluctuation Ratio	5% (Std. Value)
Speed Setting	With a Potentiometer (Analog setting)
Operating Temperature	-10°C~40°C
Storage Temperature	-20°C~60°C
Operating Humidity	85%RH or less (No condensation)

\*±10% is the voltage fluctuation range, and is not a continuously operable range.

## Motor Manufacturer A (Panasonic Motor) Induction Motor / variable Speed Motor (Single Phase)

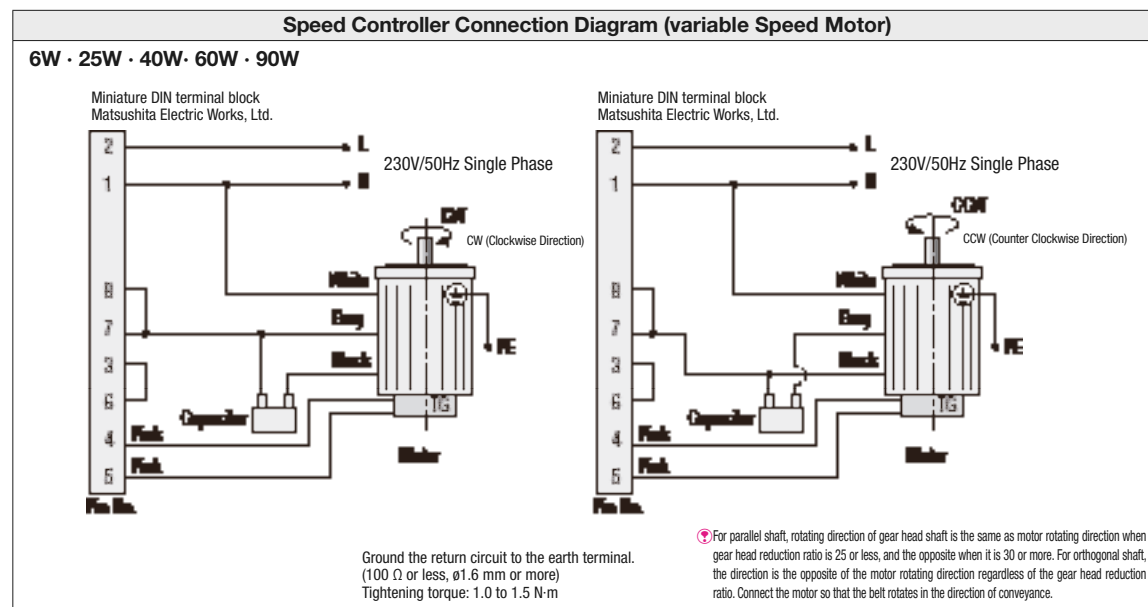
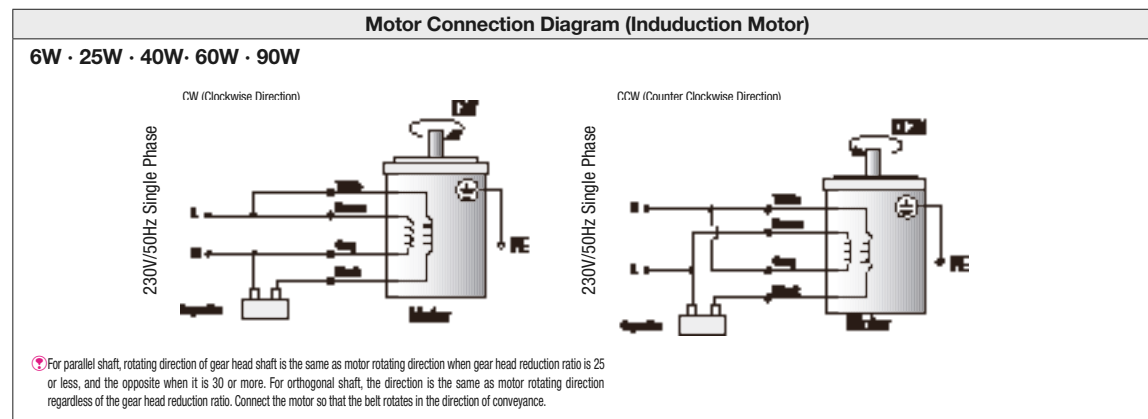

## Motor Manufacturer B (Oriental Motor)

