

MechaLock Straight

Features: Has larger maximum allowable torque than Standard Type, and locks the shaft and hub firmly. Has any part not shouldered to work the Centering function but makes applications based on several pieces easier than ever.

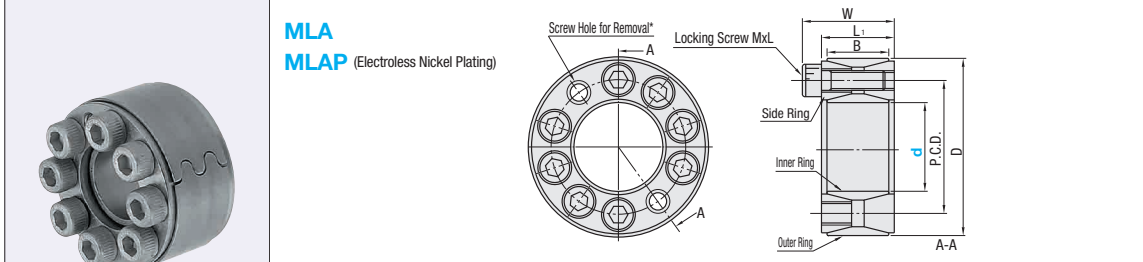

MLA
MLAP (Electroless Nickel Plating)

* Thread diameter of screw hole for removal is the same as that of locking screw.
 * Lock screw of MLA and MLAP is colored red due to coating agent.
 * When installation, press down side rings strongly and tighten with screws.

Type	Main Body
	Material Surface Treatment
MLA	EN 1.1191 Equiv. -
MLAP	Electroless Nickel Plating

Part Number	Type	d	D	W	P.C.D.	L1	B	Locking Screw			Screw Hole for Removal	Mass (g)	Unit Price	
								MxL	Qty.	Tightening Torque (N·m)			MLA	MLAP
20	MLA MLAP	20	47	26	34.5	18	M6x18	10	5	12.7	2	240		
22		230												
24		250												
25		240												
28		290												
30		280												
32		340												
35		310												
38		370												
40		350												
42		600												
45		570												
48		630												
50		610												
55		660												
60		700												
65	710													

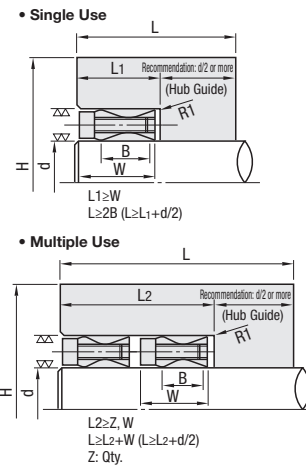

Check MechaLock for allowable load applied
For Calculation Steps, see P.1489.

d	Max. Allowable Torque (N·m)	Allowable Thrust Load (kN)
20	300	29.5
22	330	29.5
24	410	33.8
25	430	33.8
28	530	37.8
30	570	37.8
32	730	45.4
35	800	45.4
38	1010	52.9
40	1060	52.9
42	1560	74.1
45	1670	74.1
48	1780	74.1
50	1860	74.1
55	2530	91.8
60	2760	91.8
65	2990	91.8

kgf=Nx0.101972

Check Shaft/Hub for Rigidity For Design Steps, see P.1489.

d	Shaft Side Surface Pressure MPa	Side Surface Pressure of Hub MPa	Single Use				Hub Machining Depth L1	2 Hubs				Hub Machining Depth L2	
			H Hub Minimum O.D.					H Hub Minimum O.D.					
			147	206	294	392		147	206	294	392		
20	217	93	70	62	57	55	87	72	63	58	28	55	
22	198	93	70	62	57	55	83	69	62	55			
24	207	100	77	68	62	59	85	72	65	61			
25	199	100	77	68	62	59	98	82	72	67			
28	199	101	86	75	68	65	115	93	81	75			
30	186	101	86	75	68	65	109	90	79	74			
32	209	111	98	84	76	72	126	101	88	81			
35	191	111	98	84	76	72	159	123	105	96			
38	205	120	112	94	84	79	171	128	107	98			
40	195	120	112	94	84	79	170	131	112	102			
42	223	125	132	110	98	91	159	127	109	101			
45	208	125	132	110	98	91	200	147	123	111			
48	195	117	135	115	103	96	214	156	130	118			
50	187	117	135	115	103	96	211	159	134	123			
55	211	136	160	130	114	106						34	67
60	193	129	162	134	118	110							
65	178	122	165	138	123	115							

kgf/mm²=MPax0.101972

Ordering Example **Part Number**
MLA30

Recommended Tolerance of Shaft and Hub / Roughness of Surface

Mounting Surface	Tolerance	Roughness of Surface
Shaft Outer Dia.	h7(g6)	Ra1.6 or less
Hub I.D.	H7	Ra3.2 or less

MechaLock Straight for High Torque

Features: In order to withstand higher load, is made longer in axial direction than conventional Straight Type.

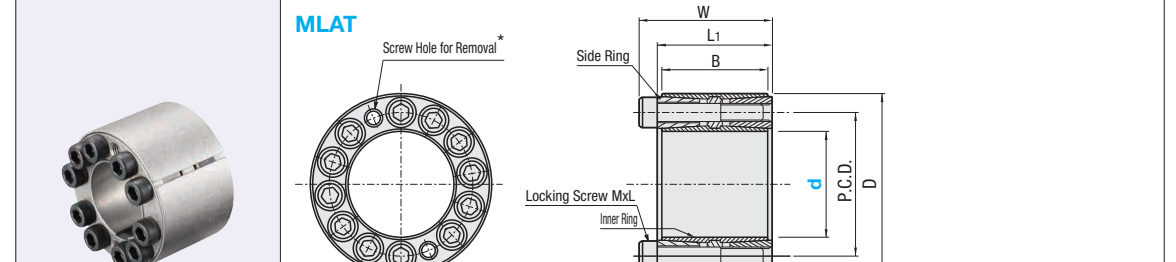

MLAT

* The thread diameter of the screw hole for removal is the same as those of the lock screw.
 * Weight of side ring itself may shrink or enlarge the inner or outer rings. When installation, loosen side rings on both sides and insert a shaft into the hub.

Type	Main Body
	Material Surface Treatment
MLAT	EN 1.1191 Equiv. -

Part Number	Type	d	D	W	P.C.D.	L1	B	Locking Screw			Screw Hole for Removal	Mass (g)	Unit Price
								MxL	Qty.	Tightening Torque (N·m)			
30	MLAT	30	44	26	42.5	38	35	M6x35	10	15.7	2	490	
35		12										560	
40		14										620	
45		14										1090	
50		12										1170	
55		58	85	50	45	70	M8x45	12	37.3	4	1250		
60			90								1340		
65			95								80	1430	

Check MechaLock for allowable load applied
For Calculation Steps, see P.1489.

Check Shaft / Hub for Rigidity.
For Design Steps, see P.1489.

d	Max. Allowable Torque (N·m)	Allowable Thrust Load (kN)
30	1110	74
35	1550	88.8
40	2070	103
45	3800	
50	4220	
55	4640	
60	5060	
65	6400	197

kgf=Nx0.101972

d	Shaft Side Surface Pressure MPa	Side Surface Pressure of Hub MPa	H Hub Minimum O.D.			Hub Machining Depth L
			206	294	392	
30	250	136	122	91	80	44
35	257	150	151	106	90	
40	262	161	187	121	101	
45	277	166	229	143	118	
50	249	156	215	145	122	
55	226	147	207	147	126	
60	208	138	204	151	131	
65	224	153	247	170	144	

kgf/mm²=MPax0.101972

Ordering Example **Part Number**
MLAT35

Recommended Tolerance of Shaft and Hub / Roughness of Surface

Mounting Surface	Tolerance	Roughness of Surface
Shaft Outer Dia.	h7(g6)	Ra1.6 or less
Hub I.D.	H7	Ra3.2 or less