

# MechaLock

## Compact (Centering Function)

■ **Features:** Is provided with the Centering function and is suitable for combination use with small-sized hubs.

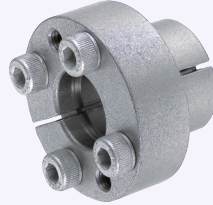

**MLR**  
**MLRP** (Electroless Nickel Plating)  
**MLRS** (Stainless Steel)

Type	Main Body
	Material Surface Treatment
MLR	EN 1.1191 Equiv. -
MLRP	EN 1.1191 Equiv. Electroless Nickel Plating
MLRS	EN 1.4301 Equiv. -

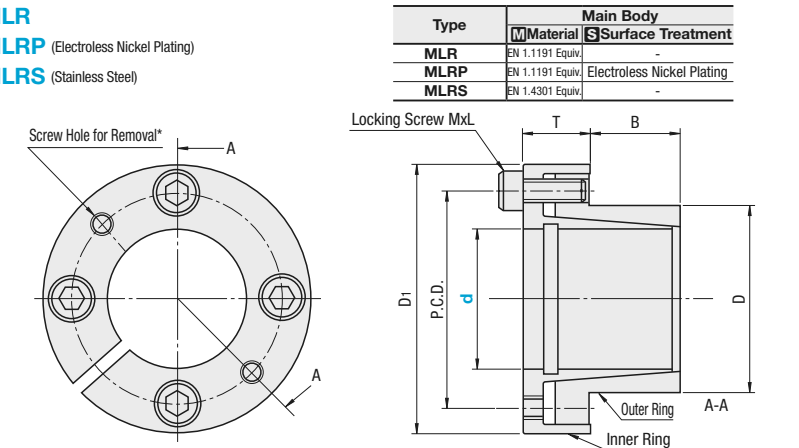

\* Thread diameter of screw hole for removal is the same as that of locking screw. Lock screw of MLR and MLRP is colored red due to coating agent.

Part Number Type	d	D	D1	P.C.D.	T	B	Locking Screw		Unit Price		
							MxL	Qty.	MLR	MLRP	MLRS
5	5	12	23	15.5	9	10	M3x8	4			
6	6	15	28	19.5	11	12	M4x10	4			
8	8	18	31.5	22.5	11	12	M4x10	5			
10	10	20	33.5	24.5	11	12	M4x10	5			
12	12	22	35.5	26.5	11	12	M4x10	5			
14	14	22	35.5	26.5	11	12	M4x10	5			
15	15	23	38.5	28.5	13	14	M5x12	4			
16	16	24	39.5	29.5	13	14	M5x12	4			
17	17	25	40.5	30.5	13	14	M5x12	4			
18	18	26	46	33	14	14	M5x12	4			
19	19	27	47	34	14	14	M5x12	4			
20	20	28	48	35	14	14	M5x12	4			
22	22	32	52	39	16	16	M6x14	4			
24	24	34	54	41	16	16	M6x14	4			
25	25	34	54	41	16	16	M6x14	4			
28	28	39	59	46	16	16	M6x14	4			
30	30	41	61	48	16	16	M6x14	4			
32	32	43	63	50	16	16	M6x14	4			
35	35	47	67	54	20	20	M8x18	4			
38	38	50	70	57	20	20	M8x18	4			
40	40	53	73	60	20	20	M8x18	4			
42	42	55	75	62	20	20	M8x18	4			
45	45	59	84	69	20.5	30	M8x18	4			
48	48	62	87	72	20.5	30	M8x18	4			
50	50	65	90	75	20.5	30	M8x18	4			

**MLR**  
**MLRP** (Electroless Nickel Plating)  
**MLRS** (Stainless Steel)

Ordering Example Part Number **MLR10**

- **Features**
- Small difference between the I.D. and O.D. makes compact design possible.
  - Hub does not move when tightened because the inner ring touches the end face of the hub.
  - It has a function (centering function) to control pendulum of the end face and the circumference of the hub against the shaft.

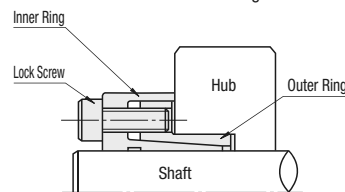

■ **Recommended Tolerance of Shaft and Hub / Roughness of Surface**

Shaft O.D.	h7(g6)	Ra1.6 or less
Hub I.D.	H7	Ra3.2 or less

■ **Allowable Load applied to MechaLock** For Design Steps, see P.1489.

Type	MLR			MLRP			MLRS			Mass (g)
	Max. Allowable Torque (N·m)	Allowable Thrust Load (kN)	Screw Tightening (N·m)	Max. Allowable Torque (N·m)	Allowable Thrust Load (kN)	Screw Tightening (N·m)	Max. Allowable Torque (N·m)	Allowable Thrust Load (kN)	Screw Tightening (N·m)	
5	9	3.45	1.7	9	3.45	1.7	3	1.05	1.1	36
6	11	6.09	4.0	11	6.09	4.0	4	1.92	2.7	34
8	25	8.71	8.0	25	8.71	8.0	8	2.75	5.6	61
10	44	15.3	14.0	44	15.3	14.0	14	7.4	9.6	78
12	53	23.2	34.8	53	23.2	34.8	17	11.1	23.6	86
14	61	46.4	84.5	61	46.4	84.5	20	14.9	1090	94
15	115	84.5	34.0	115	84.5	34.0	38	27.5	1000	135
16	123	84.5	34.0	123	84.5	34.0	41	27.5	1000	140
17	131	84.5	34.0	131	84.5	34.0	43	27.5	1000	146
18	210	84.5	34.0	210	84.5	34.0	68	27.5	1000	221
19	221	84.5	34.0	221	84.5	34.0	71	27.5	1000	228
20	233	84.5	34.0	233	84.5	34.0	75	27.5	1000	235
22	256	84.5	34.0	256	84.5	34.0	83	27.5	1000	287
24	279	84.5	34.0	279	84.5	34.0	90	27.5	1000	302
25	291	84.5	34.0	291	84.5	34.0	94	27.5	1000	293
28	488	84.5	34.0	488	84.5	34.0	157	27.5	1000	378
30	523	84.5	34.0	523	84.5	34.0	168	27.5	1000	396
32	558	84.5	34.0	558	84.5	34.0	180	27.5	1000	414
35	813	84.5	34.0	813	84.5	34.0	262	27.5	1000	484
38	883	84.5	34.0	883	84.5	34.0	284	27.5	1000	512
40	929	84.5	34.0	929	84.5	34.0	299	27.5	1000	560
42	976	84.5	34.0	976	84.5	34.0	314	27.5	1000	580
45	1910	84.5	34.0	1910	84.5	34.0	620	27.5	1000	962
48	2040	84.5	34.0	2040	84.5	34.0	670	27.5	1000	1000
50	2120	84.5	34.0	2120	84.5	34.0	690	27.5	1000	1090

kgf=Nx0.101972

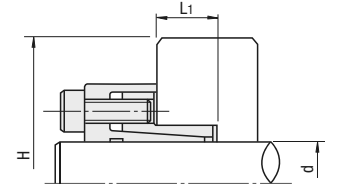

■ **Shaft/Hub Rigidity** For Design Steps, see P.1489.

d	MLR, MLRP						MLRS					
	Shaft Side Surface Pressure MPa	Side Surface Pressure MPa	H Hub Minimum O.D.			Hub Machining Depth L1	Shaft Side Surface Pressure MPa	Side Surface Pressure MPa	H Hub Minimum O.D.			Hub Machining Depth L1
			Yield Point Stress of Hub Material (MPa)						Yield Point Stress of Hub Material (MPa)			
			206	294	392				206	294	392	
5	188	99	23	23	23	12	57	30	23	23	23	12
6	156	99	23	23	23	12	48	30	23	23	23	12
8	174	116	29	28	28	14	55	37	29	28	28	14
10	193	134	40	31.5	31.5	14	61	43	31.5	31.5	31.5	14
12	161	121	40	33.5	33.5	14	51	39	33.5	33.5	33.5	14
14	138	110	40	35.5	35.5	16	44	35	35.5	35.5	35.5	16
15	178	150	58	41	38.5	16	59	49	38.5	38.5	38.5	16
16	167	144	58	42	39.5	16	55	47	39.5	39.5	39.5	16
17	158	138	57	42	40.5	16	52	46	40.5	40.5	40.5	16
18	195	198	-*	59	46	18	63	64	46	46	46	18
19	185	191	-*	59	47	18	60	62	47	47	47	18
20	176	184	-*	59	48	18	57	59	48	48	48	18
22	146	141	74	54	52	22	47	46	52	52	52	22
24	134	133	74	56	54	22	43	43	54	54	54	22
25	128	133	74	56	54	22	42	43	54	54	54	22
28	146	139	89	66	59	24	47	45	59	59	59	24
30	136	132	88	67	61	24	44	43	61	61	61	24
32	128	126	88	68	63	24	41	41	63	63	63	24
35	145	140	108	79	69	24	47	45	67	67	67	24
38	133	131	106	81	71	24	43	42	70	70	70	24
40	127	124	107	84	74	24	41	40	73	73	73	24
42	121	119	107	85	76	24	39	39	75	75	75	24
45	160	148	146	103	88	32	52	49	84	84	84	32
48	150	141	144	105	91	32	49	46	87	87	87	32
50	144	135	143	107	94	32	47	44	90	90	90	32

\* Unavailable due to excessive Side Surface Pressure

kgf/mm<sup>2</sup>=MPax0.101972