

Antivibration Rubber Mounts Stainless Steel Studs (Conductive Rubber, Chloroprene Rubber)

Both Ends Threaded Studs / Threaded Stud, Plate Mount

Antivibration Rubber Mounts Stainless Steel Studs (Conductive Rubber, Chloroprene Rubber)

Tapped and Threaded Studs / Tapped Stud, Plate Mount

The problem of antivibration rubber, susceptibility to insulation has been solved by the high electroconductive rubber with volume resistivity value of $10^9 \Omega \cdot \text{cm}$.
Slots on ends and long mounting holes for ease of attachment.

The problem of antivibration rubber, susceptibility to insulation has been solved by the high electroconductive rubber with volume resistivity value of $10^9 \Omega \cdot \text{cm}$.
Slots on ends and long mounting holes for ease of attachment.

Both Ends Threaded Studs

Type	Material		Hardness	Accessory
	Main Body	Metal Fitting		
DBGOMA	Conductive Nitrile Rubber	EN 1.4301 Equiv.	Shore A60	Nut, Spring Washer 2 pcs. each
EBGOMA	Chloroprene Rubber	EN 1.4301 Equiv.	Shore A60	Nut, Spring Washer 1 pc. each

Threaded Stud, Plate Mount

Type	Material		Hardness	Accessory
	Main Body	Metal Fitting		
DBGOMP	Conductive Nitrile Rubber	EN 1.4301 Equiv.	Shore A60	Nut, Spring Washer 1 pc. each
EBGOMP	Chloroprene Rubber	EN 1.4301 Equiv.	Shore A60	Nut, Spring Washer 1 pc. each

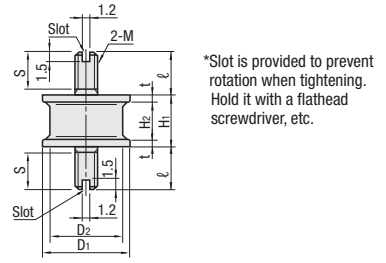

*Slot is provided to prevent rotation when tightening. Hold it with a flathead screwdriver, etc.

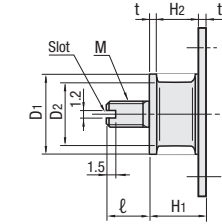
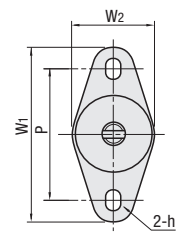

Part Number Type	No.	D1	D2	H1	H2	t	l	S	M (Coarse Thread)	W1xW2	h	P	Allowable Load N (kgf)	Working Load N (kgf)	Spring Constant N/mm (kgf/cm)	X Direction Allowable Load N (kgf)	Rigidity Ratio kx/kz
Both Ends Threaded Studs DBGOMA EBGOMA	12160	12	10	16	12.0		13	11	5	-	-	-	110 {11}	30-78 {3-8}	41 {42}	25 {2.5}	0.2
	15150	15	12		11.0	2.0	12						160 {16}	59-130 {6-13}	74 {75}	34 {3.4}	0.2
	20150			15			16						280 {29}	98-191 {10-19}	130 {130}	69 {7}	0.15
	20200	20	15	20	16.0		13		6	49x20	6.5x8.5 Slotted Hole	36	180 {18}	59-98 {6-10}	78 {80}	49 {5}	0.19
Threaded Stud, Plate Mount DBGOMP EBGOMP	25180	25	20	18	13.4		20	16		56x25		42	490 {50}	112-250 {11-25}	200 {200}	98 {10}	0.16
	30180	30	25	18	13.4	2.3	23	20	8	62x30		48	890 {91}	226-450 {23-46}	310 {310}	170 {17}	0.16
	40250	40	34	25	20.4		33	25		76x40	9x11 Slotted Hole	60	1810 {185}	196-930 {20-95}	340 {340}	360 {37}	0.17

Selection Methods, Mounting Methods, Properties, Cautions P.460

Ordering Example
Part Number
DBGOMA15150

Part Number Type	No.	Unit Price			
		DBGOMA	EBGOMA	DBGOMP	EBGOMP
Both Ends Threaded Studs DBGOMA EBGOMA	12160			-	-
	15150			-	-
	20150			-	-
	20200			-	-
Threaded Stud, Plate Mount DBGOMP EBGOMP	25180			-	-
	30180			-	-
	40250			-	-

Tapped and Threaded Studs

Type	Material		Hardness	Accessory
	Main Body	Metal Fitting		
DBGONA	Conductive Nitrile Rubber	EN 1.4301 Equiv.	Shore A60	Nut, Spring Washer 1 pc. each
EBGONA	Chloroprene Rubber	EN 1.4301 Equiv.	Shore A60	Nut, Spring Washer 1 pc. each

Tapped Stud, Plate Mount

Type	Material		Hardness
	Main Body	Metal Fitting	
DBGONP	Conductive Nitrile Rubber	EN 1.4301 Equiv.	Shore A60
EBGONP	Chloroprene Rubber	EN 1.4301 Equiv.	Shore A60

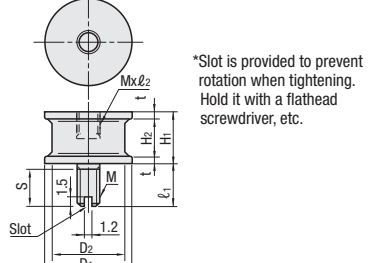

*Slot is provided to prevent rotation when tightening. Hold it with a flathead screwdriver, etc.

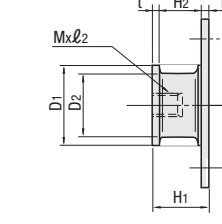
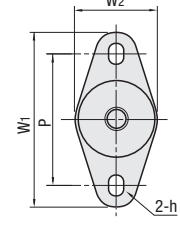

Part Number Type	No.	D1	D2	H1	H2	t	l1	S	M (Coarse Thread)	l2	W1xW2	h	P	Allowable Load N (kgf)	Standard Load N (kgf)	Spring Constant N/mm (kgf/cm)	X Direction Allowable Load N (kgf)	Rigidity Ratio kx/kz
Tapped and Threaded Studs DBGONA EBGONA	12160	12	10	16	12.0		13	11	5	4.5	-	-	-	110 {11}	30-78 {3-8}	62 {63}	25 {2.5}	0.2
	15150	15	12		11.0	2.0	12							160 {16}	59-130 {6-13}	110 {110}	34 {3.5}	0.24
	20150			15			16							280 {29}	98-160 {10-16}	180 {180}	69 {7}	0.18
	20200	20	15	20	16.0		13		6	5	49x20	6.5x8.5 Slotted Hole	36	180 {18}	59-98 {6-10}	88 {90}	49 {5}	0.22
Tapped Stud, Plate Mount DBGONP EBGONP	25180	25	20	18	13.4		20	16		6	56x25		42	580 {59}	147-280 {15-29}	220 {220}	98 {10}	0.19
	30180	30	25	18	13.4	2.3	23	20	8	7.2	62x30		48	1700 {170}	415-830 {43-85}	610 {620}	250 {25}	0.16
	40250	40	34	25	20.4		33	25			76x40	9x11 Slotted Hole	60	1420 {145}	363-700 {37-71}	340 {350}	340 {35}	0.23

Selection Methods, Mounting Methods, Properties, Cautions P.460

Ordering Example
Part Number
DBGONA15150

Part Number Type	No.	Unit Price			
		DBGONA	EBGONA	DBGONP	EBGONP
Tapped and Threaded Studs DBGONA EBGONA	12160			-	-
	15150			-	-
	20150			-	-
	20200			-	-
Tapped Stud, Plate Mount DBGONP EBGONP	25180			-	-
	30180			-	-
	40250			-	-

Features

- [DBGOMA, DBGOMP, DBGONA, DBGONP]
- The problem of antivibration rubber, susceptibility to insulation has been solved by the high electroconductive rubber with volume resistivity value of $10^9 \Omega \cdot \text{cm}$.
- [EBGOMA, EBGOMP, EBGONA, EBGONP]
- High quality product made of chloroprene rubber excellent in durability
- [Common]
- Mounting studs are made of EN 1.4301 Equiv. The tips are slotted and the mounting holes on flanges are also slotted for ease of mounting.

Electroconductive Rubber Characteristics

Item	Unit	Value
Specific Gravity	-	1.31
Hardness	Shore A	60
Elongation	%	545
Tensile Strength	MPa	11.8
Specific Volume Resistivity	$\Omega \cdot \text{cm}$	8×10^3

Measuring Method: JIS K 6301
The above values are not guaranteed values but an example of measured values.

Vibration Transmissibility Data

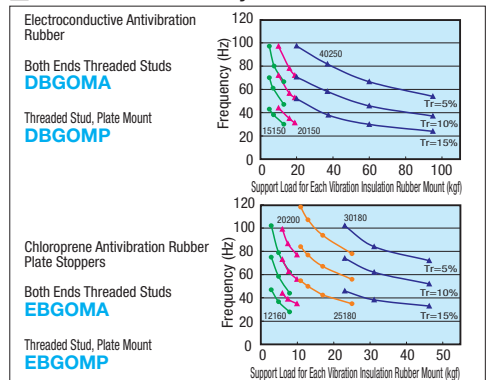

Values in the graph are nominal for each type. The above values are not guaranteed values but a calculated ones.

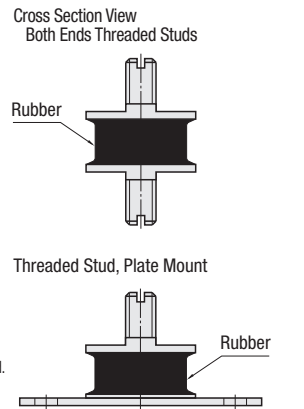
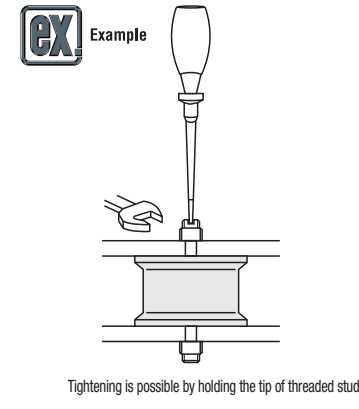

Example

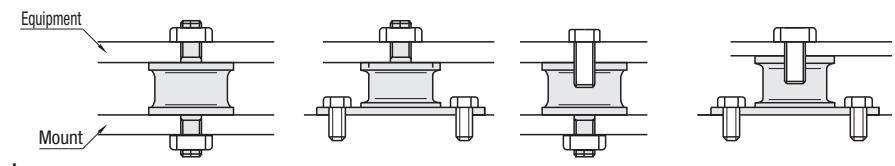

Vibration Transmissibility Data

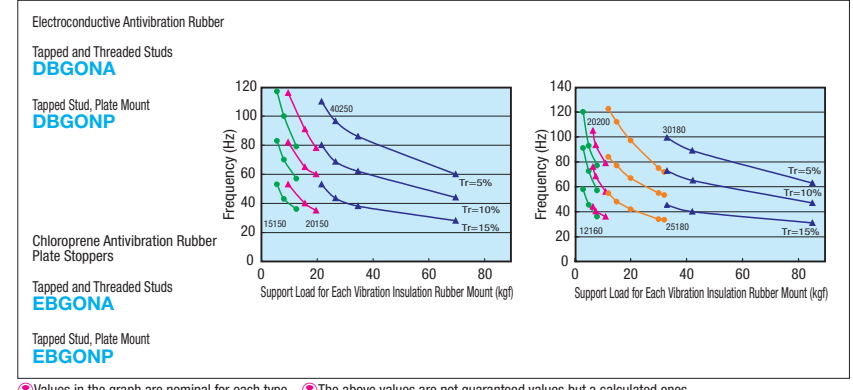

Values in the graph are nominal for each type. The above values are not guaranteed values but a calculated ones.

