

Door Units / Aluminum Extrusion Components for Doors

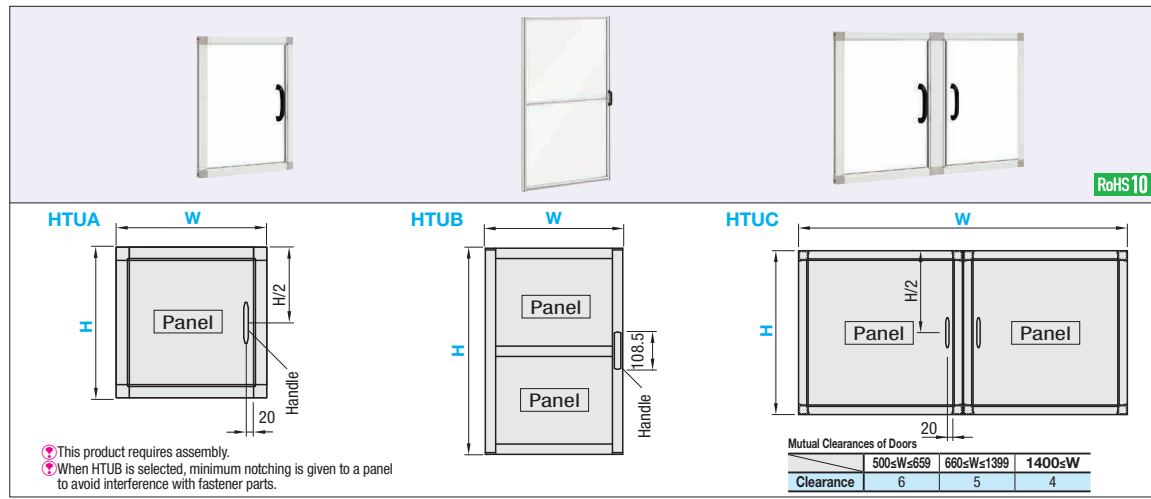

Part Number	Type	No.	Panel Selection (Select a desired material and thickness from the codes below.)		W (Width) 1mm Increment	H (Height) 1mm Increment	Components						
			AC (Thickness 5mm)	PC3 (Thickness 3mm)			Extrusion* Parts	Fastening Parts	Handle Parts	Panel Holder Parts			
HTUA	5	6	AC (Thickness 5mm)	PC3 (Thickness 3mm)	250-1000	250-1000	HFTF5-2020	HBLTC5	4	HHDS90 (Mounting Screws included)	1	HFSSK5-Length (Thickness 5mm)	4
			PC (Thickness 5mm)	PC3 (Thickness 3mm)			HFTF6-3030	HBLTC6	4	HHDS90 (Mounting Screws included)	1	HFSSK3-Length (Thickness 3mm)	4
HTUB	6	8	AC (Thickness 5mm)	PC3 (Thickness 3mm)	500-1000	1000-2000	HFS6-3030	HBLBCA6 HCJ6	4	UPCN21-B-36-SST	1	(Thickness 5mm) HSCP3H-Length (Thickness 3mm) HSCP3HN-Length	8
			PC (Thickness 5mm)	PC3 (Thickness 3mm)			HFS8-4040	HBLBCA8 HCJ8	4	UPCN26-B-41-SST	1	(Thickness 5mm) HSCP5H-Length (Thickness 3mm) HSCP7H-Length	8
HTUC	5	6	AC (Thickness 5mm)	PC3 (Thickness 3mm)	500-2000	250-1000	HFTF5-2020	HBLTC5	8	HHDS90 (Mounting Screws included)	2	(Thickness 5mm) HFSSK5-Length (Thickness 3mm) HFSSK3-Length	8
			PC (Thickness 5mm)	PC3 (Thickness 3mm)			HFTF6-3030	HBLTC6	8	HHDS90 (Mounting Screws included)	2	(Thickness 5mm) HFSSK5-Length (Thickness 3mm) HFSSK3-Length	8

* Aluminum extrusions will have hole machining required for connecting.
 Panel holders are included even with No Panel Type.

Part Number	W(mm)	H/Height						
		250-499	500-749	750-1000	1000-1249	1250-1499	1500-1749	1750-2000
HTUA	5	250-499	-	-	-	-	-	-
	6	500-749	-	-	-	-	-	-
	8	750-1000	-	-	-	-	-	-
HTUB	6	250-499	-	-	-	-	-	-
	8	500-749	-	-	-	-	-	-
	10	750-1000	-	-	-	-	-	-
HTUC	5	500-999	-	-	-	-	-	-
	6	1000-1499	-	-	-	-	-	-
	8	1500-2000	-	-	-	-	-	-

Panel Selection	Material Multiplier	
	Thickness 5mm	Thickness 3mm
AC Acrylic (Clear)	x1.0	x1.3
PC Polycarbonate (Clear)	x1.3	x0.9
PY PET (Clear)	x0.9	x1.3
ST Anti-static PVC (Clear)	x1.3	x1.1
AC3 Acrylic (Clear)	x0.9	x1.1
PC3 Polycarbonate (Clear)	x1.1	x0.9
PY3 PET (Clear)	x0.9	x1.1
ST3 Anti-static PVC (Clear)	x1.1	x0.5
NN No Panel	-	x0.5

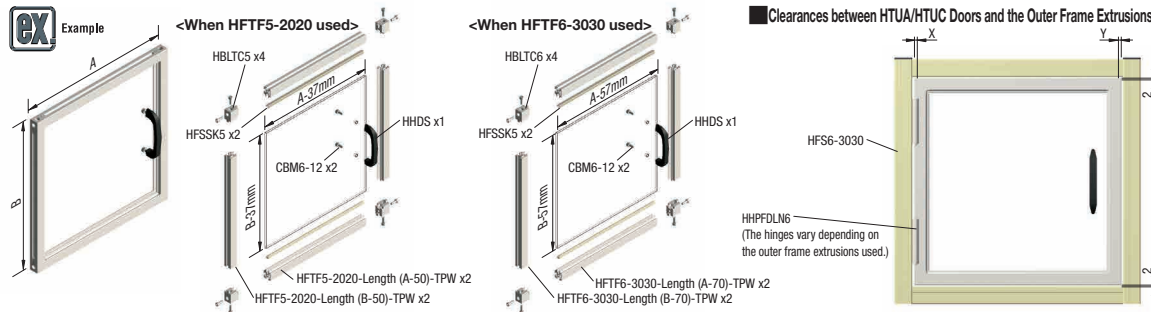

* Mount the support spacers along the circumference.
 * The door extrusions require tapping.
 * In rare occasion, you may find it difficult to insert the Panel. If that happens, use alcohol or diluted neutral detergent to insert it.

Clearance between HTUB Door and the Outer Frame Extrusions

Door Units	Hinge Type	Outer Frame Extrusions												
		30 Square (HFS6)			40 Square (HFS8)			45 Square (HFS8-45)						
Type	No.	W	H	X	Y	W	H	X	Y	W	H	X	Y	
HTUB	Hinge	A-Y-2	B-4	2	3	A-Y-2	B-4	2	3	A-Y-2	B-4	1.5	3	2
	Flag Hinge	A-Y-3.5	B-4	3.5	3	A-Y-4.5	B-4	4.5	3	A-Y-4.5	B-4	4.5	3	2

Door Units	Hinge Type	Outer Frame Extrusions							
		40 sq. (HFS8), 45 sq. (HFS8-45)				Y			
Type	No.	W	H	X	When 200sW<400	When 400sW<700	When 700sW<1000	When 1000sW	
HTUB	Hinge	A-Y-2	B-4	2	5	4	3	2	
	Flag Hinge	A-Y-4.5	B-4	4.5	5	4	3	2	

Ordering Example: Part Number - Panel - W - H
 HTUA6 - AC - 600 - 500

Alterations: Part Number - Panel - W - H - (Alteration Code)
 HTUB6 - PC - 900 - 1800 - TN

Alteration	Code	Spec.
Handles are not included.	TN	Shipped without a standard handle included. (Please use a customer provided handle.)

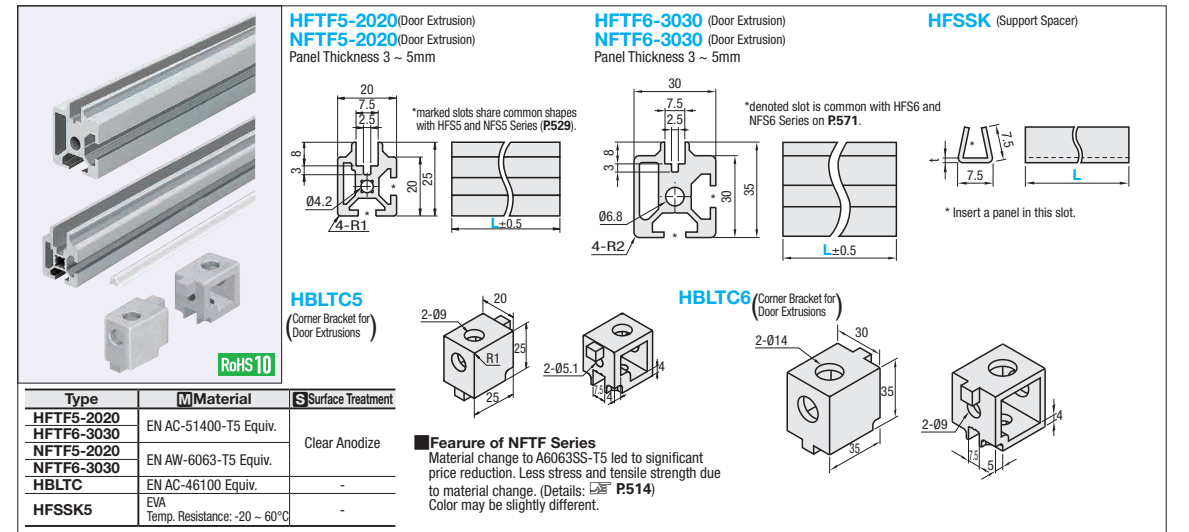

Part Number	L 0.5mm Increment	Mass kg/m	Sectional Area mm²	Applicable Panel Thickness	Cross Sectional Moment of Inertia mm⁴		Unit Price Less than 300mm	Unit Price/m 300mm or more
					ℓx	ℓy		
HFTF5-2020	50-4000	0.60	222	3-5	1.01x10⁴	0.87x10⁴		
NFTF5-2020								
HFTF6-3030								
NFTF6-3030	1.28	474	4.49x10⁴	3.83x10⁴				

Part Number	Type	No.	L Selection	Applicable Panel Thickness	t	L1000		L2000		Part Number	Mass (g)	Accessory Screw	Unit Price 1 ? 99 pc(s).	Volume Discount Rate 100-150
						Unit Price (1-9 pc(s))	Unit Price (10-50)	Unit Price (1-9 pc(s))	Unit Price (10-50)					
HFSSK	3	5	1000 2000	3	2	5	1			HBLTC	5	45	SCBE5-15	
											6	49	SCBE8-25	

* Common to HFTF5-2020, NFTF5-2020, HFTF6-3030, NFTF6-3030. For orders larger than indicated quantity, please check with WOS.

Ordering Example: Part Number - L
 NFTF5-2020 - 450
 HFTF5-2020 - 450
 HFSSK5 - 1000
 HBLTC5

The door extrusions require tapping.
 Alterations: Part Number - L - (Alteration Code)
 HFTF5-2020 - 800 - TPW

Alterations	Code Spec.	Tapping		
		LTP	RTP	TPW
Type	Tap Shape	Tapping on the Left End Face	Tapping on the Right End Face	Tapping on Both Ends
HFTF5-2020	M5-Depth15			
NFTF5-2020	M5-Depth15			
HFTF6-3030	M8-Depth24			
NFTF6-3030	M8-Depth24			