

High Flow Rate Blower Nozzles

Flat Air Nozzles / High Pressure Blowers

For Blowers

Type	Material	Heat Resistance Temp.
AFTHF	EN 1.4301 Equiv.	300°C

Features:
Structure capable of effective air blow.
Blower-based air supply enables power and air consumption saving.
This Air Nozzle is good for long time continuous air spray.

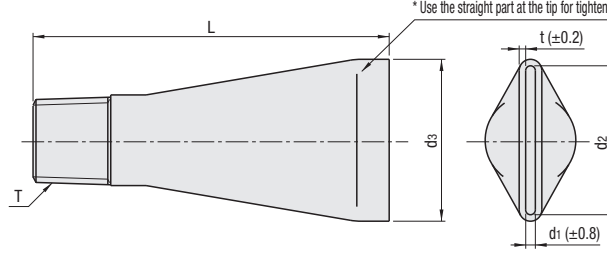
RoHS 10

The tip is slightly arc shaped due to flat forming after pipe expanding.

Part Number Type	No.	L	d1	d2	d3	t	T	Weight (g)	Volume Discount Rate		
									1 ~ 4 pc(s)	5~9	10~19
AFTHF	2	70	4	21	25	2.2	R1/4	38			
	3	70	4	25	29	2.3	R3/8	52			
	4	80	4	31	35	2.5	R1/2	82			

Ordering Example

Part Number: AFTHF2

Air Flow Rate Property Table

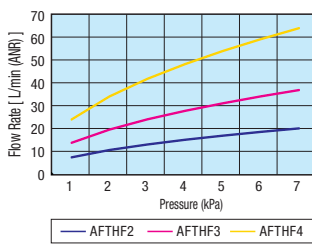

Velocity Property Table

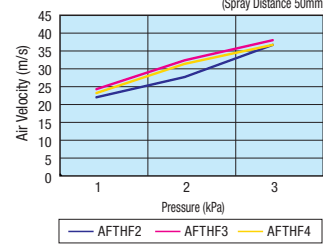

Values on the graph are for reference, not guaranteed.

Example

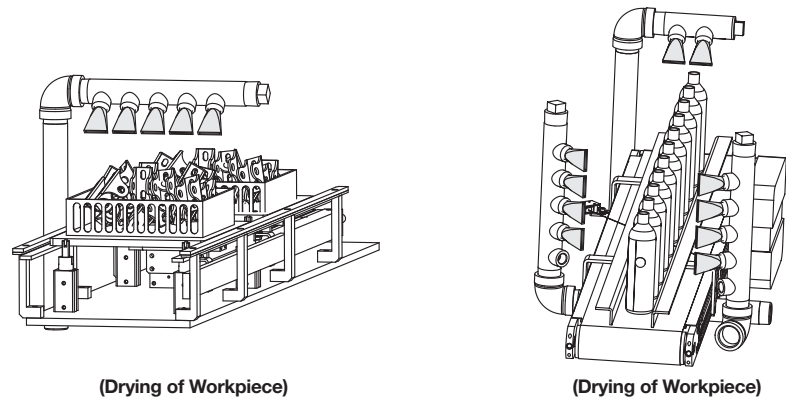

Type	Material	Max. Operating Pressure	Heat Resistance Temp.
AFTBA	EN AW-5052 Equiv.	0.7MPa	200°C

Features:
Nozzle suitable for high flow rate air blow based on blowers.
Blower-based air supply enables power and air consumption saving.
This Air Nozzle is good for long time consumption saving air spray.

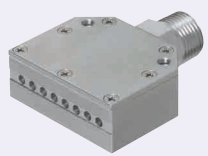
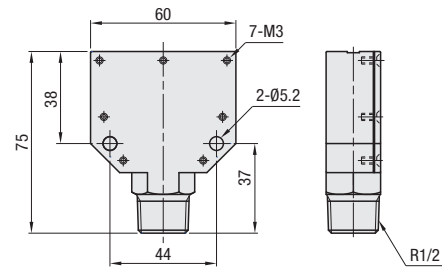



RoHS 10

Part Number Type	No.	Orifice	Weight (g)	Unit Price 1 ~ 4 pc(s)	Volume Discount Rate 5~10
AFTBA	80	8-Ø4	105		

Ordering Example

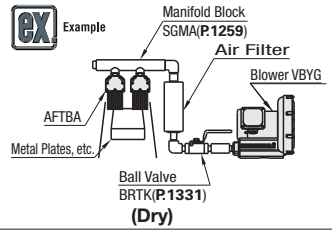
Part Number: AFTBA80



High Pressure Blowers

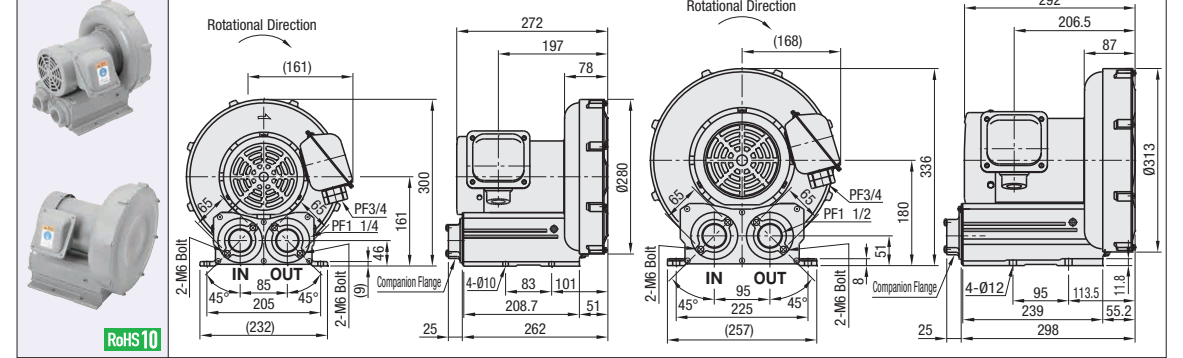

Part Number Type	Number of Phases	Power Supply Voltage (V)	Frequency (Hz)	Suction Properties				Discharge Properties				Max. Air Volume (m³/min)	Noise dB(A)	Striking Current (A)	Mass (kg)	Unit Price 1 unit
				Rated Value	Maximum	Properties	Maximum	Properties	Maximum							
3-phase	200	50	60	0.9	4.4	9.7	0.35	1.8	10.2	0.38	1.9	1.7	58	17.4(50Hz)	17.5	
				1.3	4.4	12.3	0.53	2.2	12.7	0.56	2.3	2	62	16.7(60Hz)		
3-phase	200	50	60	1.2	6.5	11.5	0.63	2.9	12.3	0.67	3.1	2.6	63	22(50Hz)	21.5	
				2	5.9	13.3	0.88	3.6	13.5	0.9	3.7	3.1	66	20(60Hz)		

Operating Range VBYE

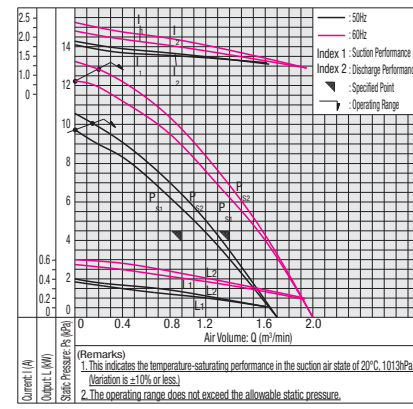

VBYG

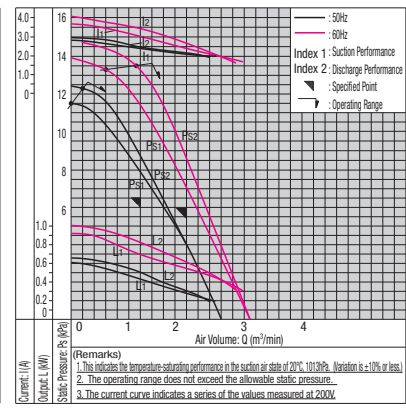

- Specifications**
- Ambient Temperature and Suction Air Temperature: -20 ~ +40°C
 - Relative Humidity: 90% or less
 - Limit suction operation to air. Do not suction fluid and corrosive / explosive gas.