



Locating Pins (Large Head)

Configurable Pilot Angle / D, P Tolerance Selectable

Ⓛ D=5 is now available for Tapped Type.



Locating Pins – Configurable Pilot Angle / D, P Tolerance Selectable

D or P	Standard Grade				Precision Grade	
	M	P	G	H	S	A
1.00	+0.008	+0.012	-0.002	0	-	-
3.00	+0.002	+0.006	-0.008	-0.010	-	-
3.01	+0.012	+0.020	-0.004	0	-	-
6.00	+0.004	+0.012	-0.012	-0.012	-	-
6.01	+0.015	+0.024	-0.005	0	+0.005	0
10.00	+0.006	+0.015	-0.014	-0.015	-	-
10.01	+0.018	+0.029	-0.006	0	-	-
18.00	+0.007	+0.018	-0.017	-0.018	-	-
18.01	+0.021	+0.035	-0.007	0	-	-
30.00	+0.008	+0.022	-0.020	-0.021	-	-

- ⊗ Precision Grade Tolerance is not available for Chrome Plated product types
- Ⓛ 440C or 420 Stainless Steel has an identification groove on D part.
- Ⓛ P-2tanA≥0.73 (Tip dia. 0.73 or more)
Reference: tan15°=0.267 tan30°=0.577
tan45°=1 tan60°=1.732

Materials No.	Material	Surface Treatment	Hardness	Type			Shape Code
				Standard	Tapped	Threaded	
(1)	O1 Tool Steel Equivalent	—	60–63 HRC min. 50–55 HRC min.	KF	KFT	KFN	A Round
(2)	O1 Tool Steel Equivalent	Chrome Plating	Plating Hardness 750 HV min.	GKF	GKFT	GKFN	
(3)	O1 Tool Steel Equivalent	—	—	BKF	BKFT	BKFN	D Diamond
(4)	304 Stainless Steel Equivalent	—	—	SKF	SKFT	SKFN	
(5)	304 Stainless Steel Equivalent	Chrome Plating	Plating Hardness 750 HV min.	HKF	HKFT	HKFN	
(6)	440C or 420 Stainless Steel	—	50–55 HRC min.	CKF	CKFT	—	

Ⓛ Refer to the price list to select the available combination.

Ⓛ When D=P,
(1) Round Shape has no relief.
(i) When D=P and tolerances are different

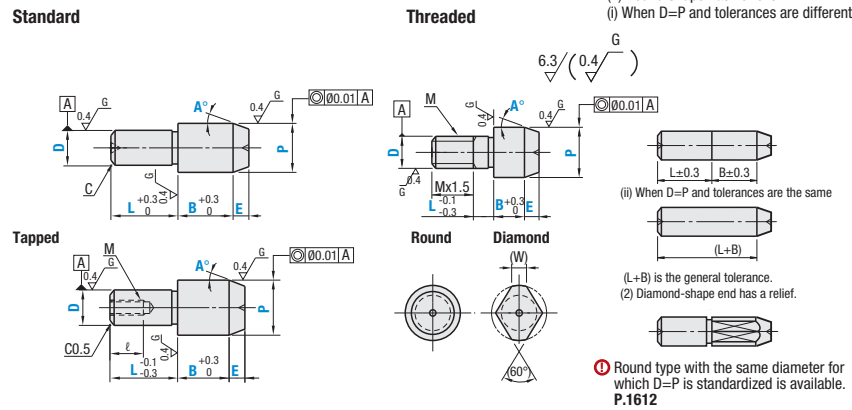

Standard

Type	Part Number		D	P	L	B	E	A	C	(W)
	Shape	D Tolerance Selection								
KF GKF* BKF SKF HKF* CKF	A Round	M P G H *A *B	1	1.00–3.00 (1.50–2.50)	2, 3	1.5–5.0	0.5–15.0	15 30 45 60	0.1	0.6
			2	2.00–6.00(4.00)	2–6	1.5–15.0(10.0)				
			3	3.00–8.00	3–10	1.5–15.0(10.0)				
			4	4.00–8.00	3(4)–14	1.5–15.0(10.0)				
			5	5.00–10.00	5–15	1.5–15.0(10.0)				
			6	6.00–10.00	5–15	1.5–30.0(15.0)				
	D Diamond	*A *B	8	8.00–15.00	5(6)–16	1.5–30.0(15.0)				
			10	10.00–17.00	5(10)–20	3.0–30.0(25.0)				
			12	12.00–18.00	6(10)–24	3.0–30.0(25.0)				
			13	13.00–20.00	7(12)–26	5.0–30.0(25.0)				
			16	16.00–27.00	8(15)–32	5.0–30.0				
			20	20.00–30.00	10(15)–40	5.0–30.0				

Ⓛ P dimension (), L dimension (), B dimension () are applicable to diamond shape. ⊗ Chrome plated is not available for Precision Grade *(Precision Grade A and B).

Tapped

Type	Part Number		D	P	L	B	E	A	(W)	M (Coarse)	ℓ
	Shape	D Tolerance Selection									
KFT BKFT SKFT HKFT CKFT	A Round	M P G H	5	5.00–8.00	5 (9)–10	1.5–15.0(12.0)	0.5–15.0	15 30 45 60	2.2	M2	3
			6	6.00–10.00	6 (9)–12	1.5–15.0(12.0)					
			6T	6.00–10.00	6 (9)–12	1.5–15.0(12.0)					
			8	8.50–15.00	8 (12)–16	1.5–30.0(15.0)					
			8T	8.50–15.00	8 (12)–16	1.5–30.0(15.0)					
			10	10.00–17.00	10 (12)–20	3.0–30.0(20.0)					
	D Diamond	H	10T	10.00–17.00	10 (12)–20	3.0–30.0(20.0)					
			12	12.00–18.00	12–24	3.0–30.0(20.0)					
			12T	12.00–18.00	8 (12)–18	3.0–30.0(20.0)					
			13	13.00–20.00	13 (14)–26	5.0–30.0(20.0)					
			13T	13.00–20.00	8 (14)–20	5.0–30.0(20.0)					
			16	16.00–27.00	16–32	5.0–30.0(27.0)					
16T	16.00–27.00	10 (14)–24	5.0–30.0(27.0)								
20	20.00–30.00	20–40	5.0–30.0								
20T	20.00–30.00	12 (18)–30	5.0–30.0								

Ⓛ Pins with D values ending in T (ex. 8T) diameter have one size smaller thread diameter and larger wall thickness. (Actual D dimension is the number without "T"). Ⓛ Note the strength of under-head part. P.1542

Ⓛ L dimension () and B dimension () are applicable to diamond shape Ⓛ Please confirm pilot hole depth on P.1542. Holes may go through.

Part Number Example

Type	Shape	D Tolerance	P Tolerance	D	P	L	B	ML
KF	A	M	S	6	P10.00	L6	B3.0	A30
GKFT	A	G	S	10T	P13.00	L6	B4.0	A15
SKFN	D	G	B	12	P15.00	L12	B5.0	A45

Part Number Alterations

Part Number	P	L	B	E	A	(MH...etc.)
KFAMS6	P10.00	L6	B3.0	E50	A30	GDC

Locating Pins (Large Head)

Configurable Pilot Angle / D, P Tolerance Selectable, *continued*

Threaded

Type	Part Number		D	P	L	B	E	A	M (Coarse)	(W)
	Shape	D Tolerance Selection								
KFN GKFN* BKFN SKFN HKFN*	A Round	M P G H *A *B	3	3.50–8.00	0–6	2.0–10.0	0.5–15.0	15 30 45 60	M3	1.5
			4	4.50–8.00	0–8	2.0–10.0				
			5	5.50–8.00	0–10	2.0–15.0(10.0)				
			6	6.50–10.00	0–10	2.0–15.0				
			8	8.50–15.00	0–10	2.0–30.0(15.0)				
			10	11.00–17.00	0–15	3.0–30.0(25.0)				
	D Diamond	*A *B	12	13.00–20.00(18.00)	0–15	3.0–30.0(25.0)				
			16	17.00–27.00	0–20	5.0–30.0				
			20	22.00–30.00	0–20	5.0–30.0				

⊗ Chrome plated is not available for Precision Grade *(Precision Grade A and B). Ⓛ For full thread, specify L = 0 and alteration NNC.

Standard

D	Available Types for Round Shape						Available Types for Diamond Shape					
	(1) O1 Tool Steel Hardened KFA	(2) Hard O1 Tool Steel GKFA	(3) O1 Tool Steel BKFA	(4) 304 Stainless Steel SKFA	(5) 304 Stainless Steel Hard HKFA	(6) 440C or 420 Stainless Steel CKFA	(1) O1 Tool Steel Hardened KFD	(2) Hard O1 Tool Steel GKFD	(3) O1 Tool Steel BKFD	(4) 304 Stainless Steel SKFD	(5) 304 Stainless Steel Hard HKFD	(6) 440C or 420 Stainless Steel CKFD
1	*	*	*	*	*	*	*	*	*	*	*	*
2	*	*	*	*	*	*	*	*	*	*	*	*
3	*	*	*	*	*	*	*	*	*	*	*	*
4	*	*	*	*	*	*	*	*	*	*	*	*
5	*	*	*	*	*	*	*	*	*	*	*	*
6	*	*	*	*	*	*	*	*	*	*	*	*
8	*	*	*	*	*	*	*	*	*	*	*	*
10	*	*	*	*	*	*	*	*	*	*	*	*
12	*	*	*	*	*	*	*	*	*	*	*	*
13	*	*	*	*	*	*	*	*	*	*	*	*
16	*	*	*	*	*	*	*	*	*	*	*	*
20	*	*	*	*	*	*	*	*	*	*	*	*

Tapped

D	Available Types for Round Shape						Available Types for Diamond Shape					
	(1) O1 Tool Steel Hardened KFTA	(2) Hard O1 Tool Steel GKFTA	(3) O1 Tool Steel BKFTA	(4) 304 Stainless Steel SKFTA	(5) 304 Stainless Steel Hard HKFTA	(6) 440C or 420 Stainless Steel CKFTA	(1) O1 Tool Steel Hardened KFTD	(2) Hard O1 Tool Steel GKFTD	(3) O1 Tool Steel BKFTD	(4) 304 Stainless Steel SKFTD	(5) 304 Stainless Steel Hard HKFTD	(6) 440C or 420 Stainless Steel CKFTD
5	*	*	*	*	*	*	*	*	*	*	*	*
6	*	*	*	*	*	*	*	*	*	*	*	*
6T	*	*	*	*	*	*	*	*	*	*	*	*
8	*	*	*	*	*	*	*	*	*	*	*	*
8T	*	*	*	*	*	*	*	*	*	*	*	*
10	*	*	*	*	*	*	*	*	*	*	*	*
10T	*	*	*	*	*	*	*	*	*	*	*	*
12	*	*	*	*	*	*	*	*	*	*	*	*
12T	*	*	*	*	*	*	*	*	*	*	*	*
13	*	*	*	*	*	*	*	*	*	*	*	*
13T	*	*	*	*	*	*	*	*	*	*	*	*
16	*	*	*	*	*	*	*	*	*	*	*	*
16T	*	*	*	*	*	*	*	*	*	*	*	*
20	*	*	*	*	*	*	*	*	*	*	*	*
20T	*	*	*	*	*	*	*	*	*	*	*	*

Threaded

D	Available Types for Round Shape					Available Types for Diamond Shape				
	(1) O1 Tool Steel Hardened KFNA	(2) Hard O1 Tool Steel GKfNA	(3) O1 Tool Steel BKfNA	(4) 304 Stainless Steel SKfNA	(5) 304 Stainless Steel Hard HKfNA	(1) O1 Tool Steel Hardened KFND	(2) Hard O1 Tool Steel GKfND	(3) O1 Tool Steel BKfND	(4) 304 Stainless Steel SKfND	(5) 304 Stainless Steel Hard HKfND
3	*	*	*	*	*	*	*	*	*	*
4	*	*	*	*	*	*	*	*	*	*
5	*	*	*	*	*	*	*	*	*	*
6	*	*	*	*	*	*	*	*	*	*
8	*	*	*	*	*	*	*	*	*	*
10	*	*	*	*	*	*	*	*	*	*
12	*	*	*	*	*	*	*	*	*	*
16	*	*	*	*	*	*	*	*	*	*
20	*	*	*	*	*	*	*	*	*	*

Alteration	Tapping	Insertion Guide Machining	Radius	Air Vent	Wrench Hole	Wrench Flat	Relief
Code	MH	GDC	RC	AC	LAC	SC	NNC
Spec.	Adds tapped hole. Ordering Code: MH RC (R0.5)	Adds Insertion Guide. Ordering Code: GDC	Changes the relief to R0.5. Ordering Code: RC	Adds an air vent. Ordering Code: AC	Machines wrench hole. -Ordering Code: LAC -Press fit is not applicable.	SC = Specified in 1mm increments -Diamond shape is not applicable - P-3≤SC≤P-1, SC≥D - If B≤11, at the tip 2 surface width processing is included. - Press fit is not applicable.	Ordering Code: NNC - Applicable when L=0 - Adds a relief at the thread end. - Cannot be used with RC