

## Double-rail carrier - BG/F 1 VPE 300 - 1200029

Please be informed that the data shown in this PDF Document is generated from our Online Catalog. Please find the complete data in the user's documentation. Our General Terms of Use for Downloads are valid (<http://download.phoenixcontact.com>)



Double-rail carrier

### Key commercial data

package_quantity	300
GTIN	4046356285636

### classifications

#### eCl@ss

eCl@ss 4.0	27110804
eCl@ss 4.1	27110804
eCl@ss 5.0	27141143
eCl@ss 5.1	27141143
eCl@ss 6.0	27141143
eCl@ss 7.0	27141143
eCl@ss 8.0	27141143

#### ETIM

ETIM 3.0	EC000326
ETIM 4.0	EC002625
ETIM 5.0	EC002625

#### UNSPSC

UNSPSC 6.01	30212109
UNSPSC 7.0901	39121708
UNSPSC 11	39121708
UNSPSC 12.01	39121708
UNSPSC 13.2	39121708

### Drawings

## Double-rail carrier - BG/F 1 VPE 300 - 1200029

Dimensioned drawing

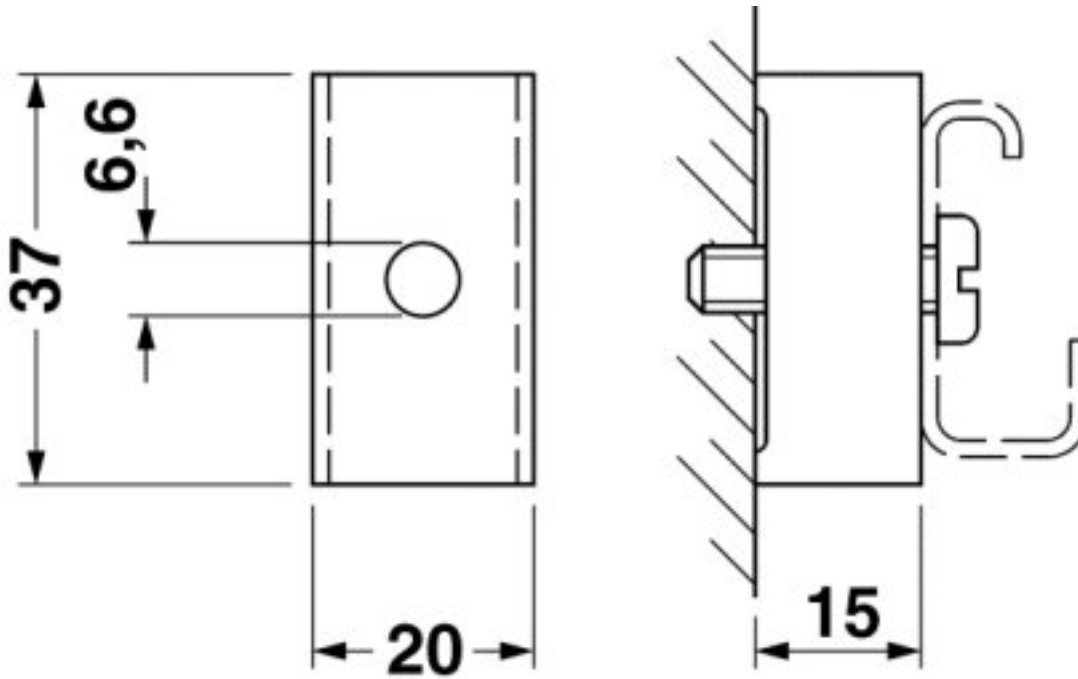

© Phoenix Contact 2013 - all rights reserved  
<http://www.phoenixcontact.com>