

RJ45 sleeve housings - VS-08-T-RJ45/IP 20 - 1688638

Please be informed that the data shown in this PDF Document is generated from our Online Catalog. Please find the complete data in the user's documentation. Our General Terms of Use for Downloads are valid (<http://download.phoenixcontact.com>)



RJ45 sleeve housing IP20, for pin insert VS-08-ST-RJ45, with push-pull interlocking for panel mounting frames, for cable cross section 5.0 mm ... 6.5 mm

Ethernet

Key commercial data

package_quantity	5
GTIN	4017918607920

Technical data

Mechanical characteristics

Insertion/withdrawal cycles	≥ 750
External cable diameter	5 mm ... 6.5 mm
Cable exit	Straight
Color	gray

Ambient conditions

Ambient temperature (operation)	-40 °C ... 80 °C
Degree of protection	IP20

Material data

Inflammability class according to UL 94	V0
Housing material	PA

classifications

eCl@ss

eCl@ss 4.0	27140816
eCl@ss 4.1	27260701
eCl@ss 5.0	27260701
eCl@ss 5.1	27260701
eCl@ss 6.0	27260705
eCl@ss 7.0	27440309
eCl@ss 8.0	27440309

ETIM

ETIM 2.0	EC000764
----------	----------

RJ45 sleeve housings - VS-08-T-RJ45/IP 20 - 1688638

classifications

ETIM

ETIM 3.0	EC001121
ETIM 4.0	EC001121
ETIM 5.0	EC002641

UNSPSC

UNSPSC 6.01	31261501
UNSPSC 7.0901	31261501
UNSPSC 11	31261501
UNSPSC 12.01	31261501
UNSPSC 13.2	31261501

accessories

Male insert

VS-08-ST-RJ45 - 1688573



Drawings

RJ45 sleeve housings - VS-08-T-RJ45/IP 20 - 1688638

Dimensioned drawing

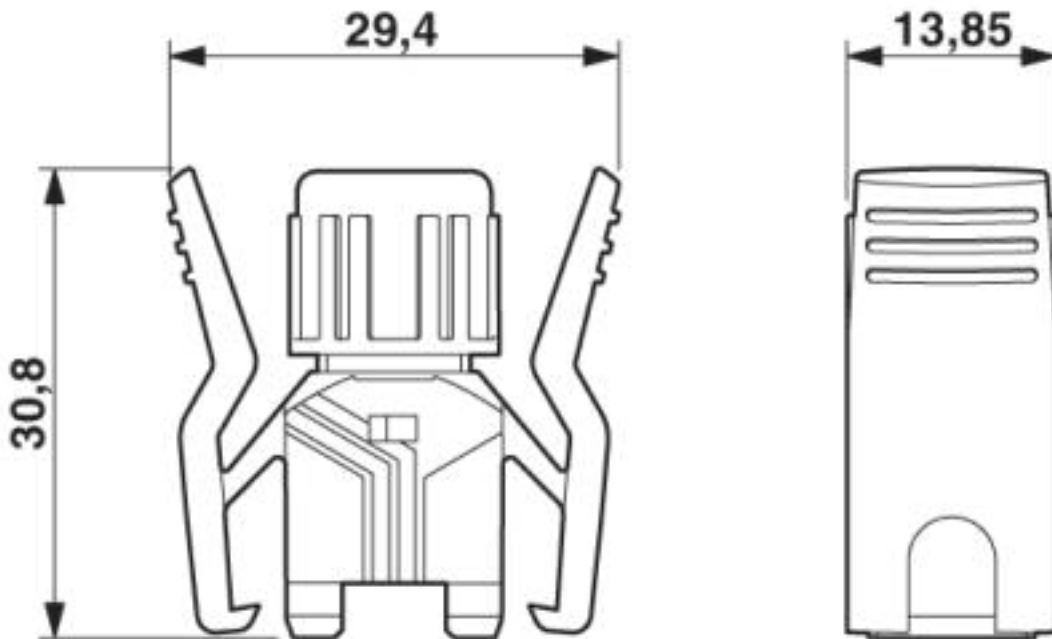

RJ45 sleeve housing, IP20

© Phoenix Contact 2013 - all rights reserved
<http://www.phoenixcontact.com>