

# Interface module - FLKM-D 9 SUB/B/LA - 2281678

Please be informed that the data shown in this PDF Document is generated from our Online Catalog. Please find the complete data in the user's documentation. Our General Terms of Use for Downloads are valid (<http://download.phoenixcontact.com>)



VARIOFACE module, with screw connection and D-Subminiature socket strip, for mounting on NS 35/7.5 or NS 32, with light indicator, 9-pos.

The illustration shows version FLKM-D37 SUB/B/LA



## Key commercial data

package_quantity	10
GTIN	4017918054922

## Technical data

### Dimensions

Width	45 mm
Height	77 mm
Depth	58.5 mm

### Ambient conditions

Ambient temperature (operation)	-20 °C ... 50 °C
Ambient temperature (storage/transport)	-20 °C ... 70 °C

### General

Nominal voltage $U_N$	24 V DC
Max. current carrying capacity per branch	2.5 A
Number of positions	9
Status display	LED
Test voltage	500 V (50 Hz, 1 min.)
Mounting position	Any
Standards/regulations	IEC 60664
Standards/regulations	DIN EN 50178
Standards/regulations	IEC 62103
Pollution degree	2
Surge voltage category	II

### Connection data for connection 1

Connection name	PCB connection
-----------------	----------------

# Interface module - FLKM-D 9 SUB/B/LA - 2281678

## Technical data

### Connection data for connection 1

Connection in acc. with standard	IEC / EN
Connection method	Screw connection
Conductor cross section solid min.	0.2 mm <sup>2</sup>
Conductor cross section solid max.	4 mm <sup>2</sup>
Conductor cross section stranded min.	0.2 mm <sup>2</sup>
Conductor cross section stranded max.	2.5 mm <sup>2</sup>
Conductor cross section AWG/kcmil min.	24
Conductor cross section AWG/kcmil max	12
Stripping length	8 mm
Screw thread	M3

## classifications

### eCl@ss

eCl@ss 4.0	27250313
eCl@ss 4.1	27250313
eCl@ss 5.0	27250313
eCl@ss 5.1	27250313
eCl@ss 6.0	27242608
eCl@ss 7.0	27141152
eCl@ss 8.0	27141152

### ETIM

ETIM 2.0	EC001434
ETIM 3.0	EC001604
ETIM 4.0	EC001604
ETIM 5.0	EC002780

### UNSPSC

UNSPSC 6.01	30211824
UNSPSC 7.0901	39121421
UNSPSC 11	39121421
UNSPSC 12.01	39121421
UNSPSC 13.2	39121421

## approvals

GOST /

Approval details

## Interface module - FLKM-D 9 SUB/B/LA - 2281678

approvals



accessories

### System cable

CABLE-D 9SUB/B/S/ 50/KONFEK/S - 2299987



CABLE-D 9SUB/B/S/100/KONFEK/S - 2299990



CABLE-D 9SUB/B/S/150/KONFEK/S - 2300009



CABLE-D 9SUB/B/S/200/KONFEK/S - 2302010



CABLE-D 9SUB/B/S/300/KONFEK/S - 2302023



## Interface module - FLKM-D 9 SUB/B/LA - 2281678

### accessories

---

CABLE-D 9SUB/B/S/400/KONFEK/S - 2302036



CABLE-D 9SUB/B/S/600/KONFEK/S - 2302049



CABLE D-SUB-S/.../.../... - 2302340



CABLE D-SUB-S-S-S/.../.../... - 2302434



CABLE-D- 9SUB/M/OE/0,25/S/0,5M - 2926360



## Interface module - FLKM-D 9 SUB/B/LA - 2281678

### accessories

CABLE-D- 9SUB/M/OE/0,25/S/1,0M - 2926373



CABLE-D- 9SUB/M/OE/0,25/S/1,5M - 2926386



CABLE-D- 9SUB/M/OE/0,25/S/2,0M - 2926399



CABLE-D- 9SUB/M/OE/0,25/S/3,0M - 2926409



CABLE-D- 9SUB/M/OE/0,25/S/4,0M - 2926412



CABLE-D- 9SUB/M/OE/0,25/S/6,0M - 2926425



# Interface module - FLKM-D 9 SUB/B/LA - 2281678

accessories

CABLE-D- 9SUB-M-OE-0,25-S/... - 2900909



## Drawings

Circuit diagram

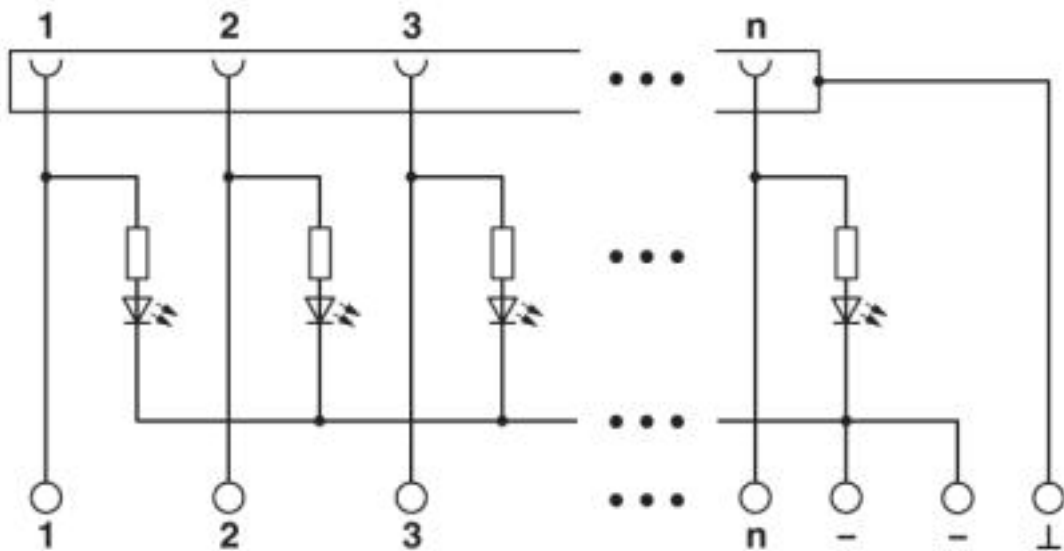

## Interface module - FLKM-D 9 SUB/B/LA - 2281678

Schematic diagram

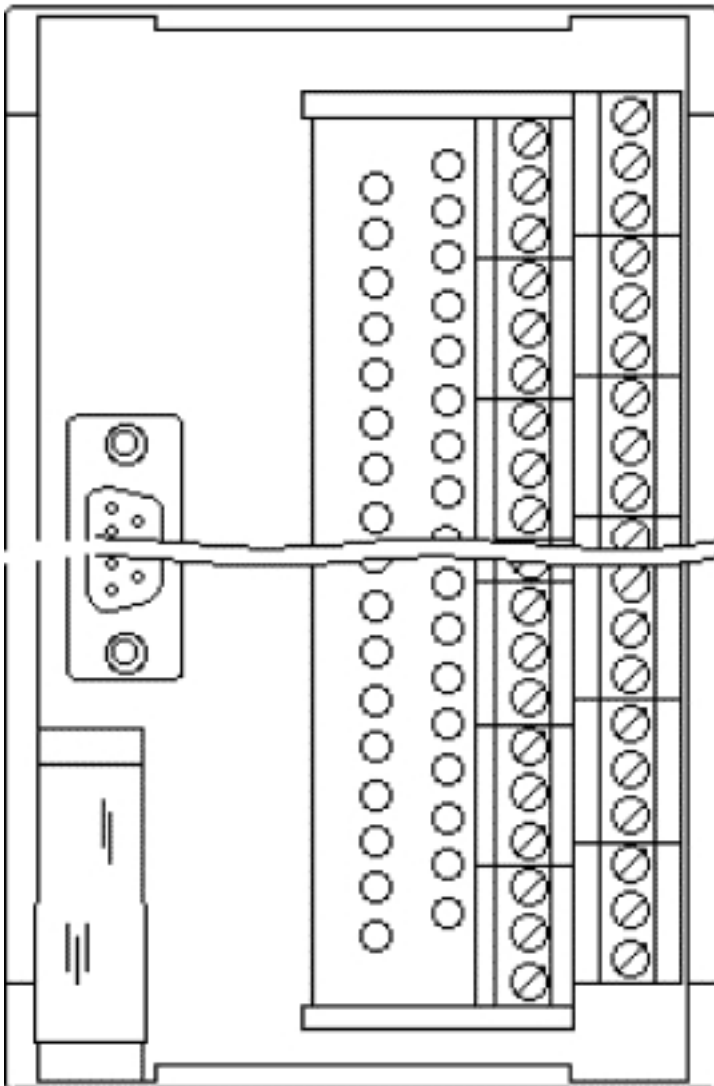

© Phoenix Contact 2013 - all rights reserved  
<http://www.phoenixcontact.com>