

## Electronic housing - UMK-BE 22,5 - 2970028

Please be informed that the data shown in this PDF Document is generated from our Online Catalog. Please find the complete data in the user's documentation. Our General Terms of Use for Downloads are valid (<http://phoenixcontact.com/download>)

Electronic board base, plug-in module base element



### Why buy this product

- ✓ The modules can be marked using the marking grooves in the lateral element as well as with the Phoenix Contact PMB module marker, which is snapped into a bore hole (4 mm Ø) in the PCB
- ✓ Fast assembly thanks to the plug-in module principle. The tight engagement of the individual elements ensures that they are securely connected.
- ✓ Wide range of options for external conductor connection
- ✓ Due to the universal foot, the modules can be snapped onto standard EN DIN rails
- ✓ The mounting flange supports direct wall mounting

### Key Commercial Data

Packing unit	10 STK
Minimum order quantity	10 STK
GTIN	 4 017918 087555
GTIN	4017918087555
Weight per Piece (excluding packing)	9.610 g
Weight per piece (including packing)	9.610 g
Custom tariff number	85472000
Country of origin	Poland
Sales Key	F1 - Electronic Housing

### Technical data

#### General

Housing type	Panel mounting base
Housing material	Polyamide

# Electronic housing - UMK-BE 22,5 - 2970028

## Technical data

### General

Color (RAL)	green
-------------	-------

### Ambient conditions

Ambient temperature (operation)	-40 °C ... 105 °C
---------------------------------	-------------------

### Dimensions

Length	77 mm
Width	22.5 mm
Depth	77 mm

### Standards and Regulations

Flammability rating according to UL 94	V2
--	----

### Environmental Product Compliance

China RoHS	Environmentally friendly use period: unlimited = EFUP-e
	No hazardous substances above threshold values

## Drawings

Dimensional drawing

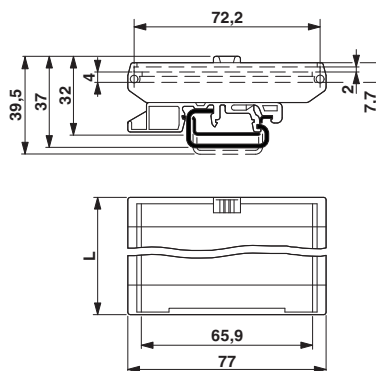

## Classifications

### eCl@ss

eCl@ss 4.0	27180401
eCl@ss 4.1	27180401
eCl@ss 5.0	27180506
eCl@ss 5.1	27180506
eCl@ss 6.0	27180802
eCl@ss 7.0	27182701
eCl@ss 8.0	27182701
eCl@ss 9.0	27182701

# Electronic housing - UMK-BE 22,5 - 2970028

## Classifications

### ETIM

ETIM 2.0	EC001031
ETIM 3.0	EC001031
ETIM 4.0	EC001031
ETIM 5.0	EC002779
ETIM 6.0	EC002779

### UNSPSC

UNSPSC 6.01	31261501
UNSPSC 7.0901	31261501
UNSPSC 11	31261501
UNSPSC 12.01	31261501
UNSPSC 13.2	31261501

## Approvals

### Approvals

---

#### Approvals

UL Recognized

---

#### Ex Approvals

---

### Approval details

UL Recognized		<a href="http://database.ul.com/cgi-bin/XYV/template/LISEXT/1FRAME/index.htm">http://database.ul.com/cgi-bin/XYV/template/LISEXT/1FRAME/index.htm</a>	FILE E 240868
---------------	--	---	---------------

## Accessories

### Accessories

Component housing lower part

Electronic housing - UMK-BE 45 - 2970015

Electronic board base, plug-in module base element



## Electronic housing - UMK-BE 22,5 - 2970028

### Accessories

Electronic housing - UMK-BE 11,25 - 2971535

Electronic board base, plug-in module base element



---

### Mounting material

Foot element - UMK-FE - 2970031

Foot element, for mounting on DIN rail NS 32 or DIN rail NS 35/7.5, can be inserted between base and side element



---

Mounting flange - UMK-BF - 2976077

Mounting flange, for mounting directly on the wall

