

Data sheet | Item number: 855-301/050-103

Plug-in current transformer; Primary rated current: 50 A; Secondary rated current: 1 A; Rated power: 1.25 VA; Accuracy class: 3

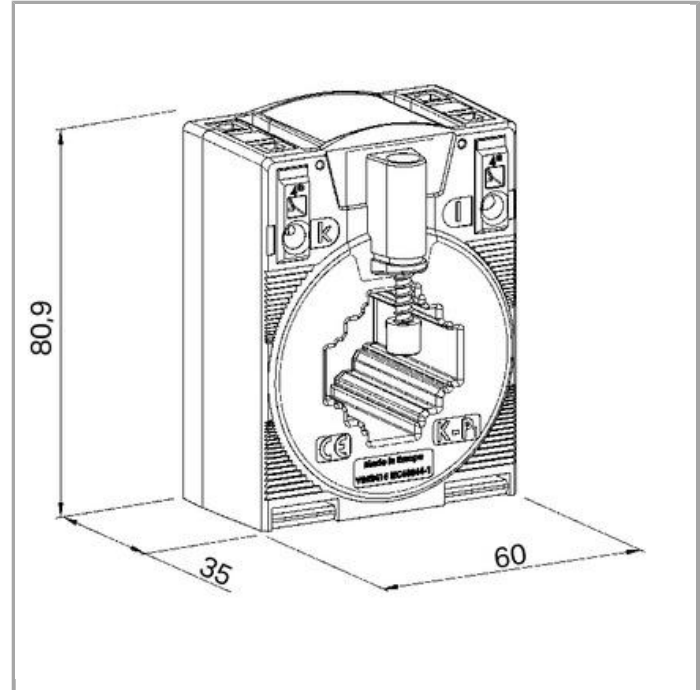

www.wago.com/855-301/050-103



RoHS
Compliant ✓

BOMcheck.net

Item description

Short description:

The 855 Series Plug-In Current Transformers are inductive, single-conductor current transformers. Due to the measurement principle used, these current transformers are exclusively designed for AC network applications.

Features:

- Screwless CAGE CLAMP® connection technology
- Several mounting options available
- Vibration- and shock-resistant
- High mechanical retention forces
- High current-carrying capacity
- Continuous overload of 120 % the nominal primary current

- Low-voltage current transformer for operating voltages up to max. 1.2 kV
- Can be used in 690 V power networks
- UL recognized components

Data

Technical Data

Input – current transformer

Primary rated current	50 A
Rated continuous thermal current I_{cth}	$1.2 \times I_N$
Rated short-time thermal current I_{th}	$60 \times I_N / 1 \text{ s}$ (max.100 kA/1 s)
Overcurrent limiting factor	FS5 / FS10 (type dependent, see type plate inscription)
Rated frequency	50 ... 60 Hz

Output – Current transformer

Secondary rated current	1 A
Rated power S_r	1.25 VA
Highest voltage for equipment U_m	1.2 kV _{rms} AC

Measurement error

Accuracy class	3
----------------	---

Safety and protection:

Test voltage	6 kV AC; 50Hz; 1min
--------------	---------------------

Connection data

Connection technology	CAGE CLAMP®
Solid conductor	0.08 ... 4 mm ² / 28 ... 12 AWG
Fine-stranded conductor	0.08 ... 4 mm ² / 28 ... 12 AWG
Strip length	9 ... 10 mm / 0.35 ... 0.39 Inch

Geometrical Data

Width	60 mm / 2.362 inch
Height	80.9 mm / 3.185 inch
Depth	52 mm / 2.047 inch

Mechanical data

Type of mounting	Current transformers (closed) Secured to mounting plate Mounting on carrier rail via carrier rail adapter Mounting on round cable
------------------	--

Material Data

Insulation class	E
Weight	230 g

Environmental Requirements

Surrounding air (operating) temperature	-5 ... 50 °C
Surrounding air (storage) temperature	-25 ... 70 °C
Max. operating altitude	1000 m

Standards and specifications

Conformity marking	CE
Standards/specifications	EN 61869-1; EN 61869-2; UL: E356480

Commercial data

Country of origin	DE
GTIN	4050821614654
Customs Tariff No.	85043129900

Approvals / Certificates

UL-Approvals

Logo	Approval	Certificate name
	UL UL Multiple Listings Project Handler	E356480

Compatible products

tools



Item no.: 210-720
Operating tool with partially insulated shaft; Type 2, blade (3.5 x 0.5) mm

www.wago.com/210-720

assembling

Item no.: 855-9900



Carrier rail adapter

www.wago.com/855-9900



Item no.: 855-9910
Quick-mount kit

www.wago.com/855-9910

General accessories



Item no.: 2007-8873
Compact terminal block; for current and voltage transformers

www.wago.com/2007-8873



Item no.: 2007-8874
Compact terminal block; for current and voltage transformers

www.wago.com/2007-8874



Item no.: 2007-8875
Compact terminal block; for current transformer circuit

www.wago.com/2007-8875



Item no.: 2007-8876
Compact terminal block; for 3-phase current transformer circuit

www.wago.com/2007-8876



Item no.: 2007-8877
Compact terminal block; for current transformer circuit

www.wago.com/2007-8877



Item no.: 857-550
Current signal conditioner; Current input signal; Current and voltage output signal; Digital output;
Configuration via software; Supply voltage: 24 VDC; 6 mm module width

www.wago.com/857-550

Downloads

Documentation

Instruction Leaflet

Bushing Type Current Transformer	Mar 16, 2015	PDF 1.5 MB	Download
----------------------------------	--------------	---------------	----------

Additional Information

Disposal; Electrical and electronic equipment, Packaging	Oct 15, 2018	265.8 kB	Download
--	--------------	----------	----------

Engineering-Software

Software for Interface-Products

Interface Configuration Software SMALL The full setup only includes the WAGO Interface Configuration Software.	1.5.4.6 Jan 8, 2018	EXE 46.0 MB	Download
---	------------------------	----------------	----------

Interface Configuration Software FULL The full setup, in addition to the WAGO Interface Configuration Software, includes the installation for the Microsoft .NET Framework.	1.5.4.6 Jan 8, 2018	EXE 96.5 MB	Download
--	------------------------	----------------	----------



smartDATA

CAD data

3D Download 855-301/050-103

[Download](#)

Subject to changes.