

Stops· soft
1586.050

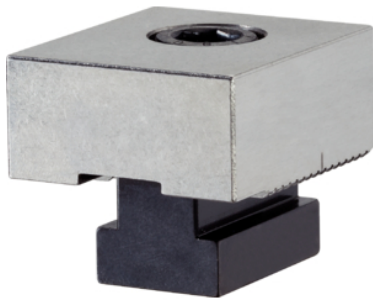

Product Description

The chucks can be machined to the needed workpiece contour.

Material

- Tool steel

Drawing

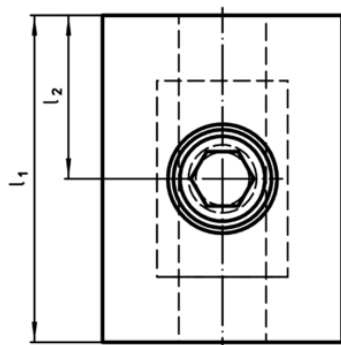
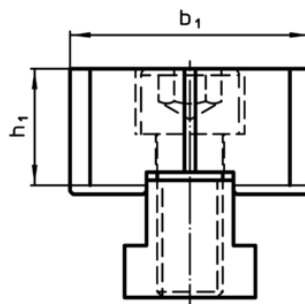
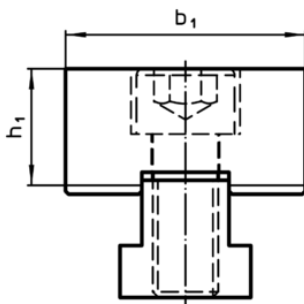

picture 1

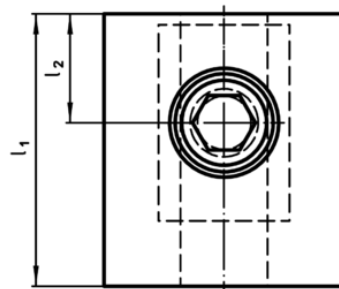

picture 2

Order information

l ₁	l ₂	Dimensions		[g]	Art. No.
		b ₁ [mm]	h ₁		
soft, on both sides – picture 1					
60	30	44	21,4	550	1586.050